

**Fire-LITE<sup>®</sup>**  
**ALARMS Inc.**  
12 Clintonville Road, Northford, CT 06472

# *Technical Manual*



## ***MS-9200*** ***Addressable Fire Control Panel*** ***(Export Version)***

## Installation Precautions - Adherence to the following will aid in problem-free installation with long-term reliability:

**WARNING** - Several different sources of power can be connected to the fire alarm control panel. Disconnect all sources of power before servicing. Control unit and associated equipment may be damaged by removing and/or inserting cards, modules, or interconnecting cables while the unit is energized. Do not attempt to install, service, or operate this unit until this manual is read and understood.

**CAUTION** - *System Reacceptance Test after Software Changes:* To ensure proper system operation, this product must be tested in accordance with NFPA 72-1993 Chapter 7 after any programming operation or change in site-specific software. Reacceptance testing is required after any change, addition or deletion of system components, or after any modification, repair or adjustment to system hardware or wiring.

All components, circuits, system operations, or software functions known to be affected by a change must be 100% tested. In addition, to ensure that other operations are not inadvertently affected, at least 10% of initiating devices that are not directly affected by the change, up to a maximum of 50 devices, must also be tested and proper system operation verified.

This system meets NFPA requirements for operation at 0-49° C/32-120° F and at a relative humidity of 85% RH (non-condensing) at 30° C/86° F. However, the useful life of the system's standby batteries and the electronic components may be adversely affected by extreme temperature ranges and humidity. Therefore, it is recommended that this system and its peripherals be installed in an environment with a nominal room temperature of 15-27° C/60-80° F.

Verify that wire sizes are adequate for all initiating and indicating device loops. Most devices cannot tolerate more than a 10% I.R. drop from the specified device voltage.

Like all solid state electronic devices, this system may operate erratically or can be damaged when subjected to lightning induced transients. Although no system is completely immune from lightning transients and interferences, proper grounding will reduce susceptibility. Overhead or outside aerial wiring is not recommended, due to an increased susceptibility to nearby lightning strikes. Consult with the Technical Services Department if any problems are anticipated or encountered.

Disconnect AC power and batteries prior to removing or inserting circuit boards. Failure to do so can damage circuits.

Remove all electronic assemblies prior to any drilling, filing, reaming, or punching of the enclosure. When possible, make all cable entries from the sides or rear. Before making modifications, verify that they will not interfere with battery, transformer, and printed circuit board location.

Do not tighten screw terminals more than 9 in-lbs. Over tightening may damage threads, resulting in reduced terminal contact pressure and difficulty with screw terminal removal.

This system contains static-sensitive components. Always ground yourself with a proper wrist strap before handling any circuits so that static charges are removed from the body. Use static suppressive packaging to protect electronic assemblies removed from the unit.

Follow the instructions in the installation, operating, and programming manuals. These instructions must be followed to avoid damage to the control panel and associated equipment. FACP operation and reliability depend upon proper installation.

## Fire Alarm System Limitations

*While installing a fire alarm system may make lower insurance rates possible, it is not a substitute for fire insurance!*

An automatic fire alarm system - typically made up of smoke detectors, heat detectors, manual pull stations, audible warning devices, and a fire alarm control with remote notification capability can provide early warning of a developing fire. Such a system, however, does not assure protection against property damage or loss of life resulting from a fire.

Any fire alarm system may fail for a variety of reasons:

**Smoke detectors** may not sense fire where smoke cannot reach the detectors such as in chimneys, in walls, or roofs, or on the other side of closed doors. Smoke detectors also may not sense a fire on another level or floor of a building. A second floor detector, for example, may not sense a first floor or basement fire. Furthermore, all types of smoke detectors - both ionization and photoelectric types, have sensing limitations. No type of smoke detector can sense every kind of fire caused by carelessness and safety hazards like smoking in bed, violent explosions, escaping gas, improper storage of flammable materials, overloaded electrical circuits, children playing with matches, or arson.

**IMPORTANT!** *Smoke detectors must be installed in the same room as the control panel and in rooms used by the system for the connection of alarm transmission wiring, communications, signaling, and/or power.* If detectors are not so located, a developing fire may damage the alarm system, crippling its ability to report a fire.

**Audible warning devices** such as bells may not alert people if these devices are located on the other side of closed or partly open doors or are located on another floor of a building.

A fire alarm system will not operate without any electrical power. If AC power fails, the system will operate from standby batteries only for a specified time.

**Rate-of-Rise heat detectors** may be subject to reduced sensitivity over time. For this reason, the rate-of-rise feature of each detector should be tested at least once per year by a qualified fire protection specialist.

**Equipment used in the system** may not be technically compatible with the control. It is essential to use only equipment listed for service with your control panel.

**Telephone lines** needed to transmit alarm signals from a premise to a central monitoring station may be out of service or temporarily disabled.

**The most common cause** of fire alarm malfunctions, however, is inadequate maintenance. All devices and system wiring should be tested and maintained by professional fire alarm installers following written procedures supplied with each device. System inspection and testing should be scheduled monthly or as required by National and/or local fire codes. Adequate written records of all inspections should be kept.

## FCC Warning

**WARNING:** This equipment generates, uses, and can radiate radio frequency energy and if not installed and used in accordance with the instruction manual, may cause interference to radio communications. It has been tested and found to comply with the limits for class A computing device pursuant to Subpart B of Part 15 of FCC Rules, which is designed to provide reasonable protection against such interference when operated in a commercial environment. Operation of this equipment in a residential area is likely to cause interference, in which case the user will be required to correct the interference at his own expense.

### Canadian Requirements

This digital apparatus does not exceed the Class A limits for radiation noise emissions from digital apparatus set out in the Radio Interference Regulations of the Canadian Department of Communications.

Le présent appareil numérique n'émet pas de bruits radioélectriques dépassant les limites applicables aux appareils numériques de la classe A prescrites dans le Règlement sur le brouillage radioélectrique édicté par le ministère des Communications du Canada.

# Table of Contents

NFPA Standards	5
Underwriters Laboratories	5
I. System Overview	7
1.0 Description	7
1.1 Features	7
1.2 Specifications	8
1.3 Controls and Indicators	9
1.4 Components	10
1.5 Optional Interface Modules	13
1.6 Accessories	14
II. Installation	19
2.0 General	19
2.1 Cabinet Dimensions	19
2.2 Backbox Mounting	20
2.3 Power	21
Figure 2.1: DC Power Output Connections	21
2.4 Standard Relays	22
Figure 2.2: Relay Connections	22
2.5 Output Circuits	22
Figure 2.3: Circuit Connections	22
2.6 UL Power-limited Wiring Requirements	23
Figure 2.4: Typical Wiring Diagram for UL Power-limiting	23
2.6.1 RTM-8F Wiring	23
2.7 Wiring the Signaling Line Circuit	24
Table 2.1: Communications Loop Performance	24
Figure 2.5: Style 4: T-tapping Restrictions and Branch Resistance	25
Figure 2.6: Style 6 Wiring	25
Figure 2.7: Two Wire Communications Loop (Supervised & Power-limited)	26
Figure 2.8: Four Wire Communications Loop (Supervised & Power-limited)	27
Figure 2.9: Four Wire Communications Loop	28
Figure 2.10: Shield Termination in No Conduit	29
Figure 2.11: Shield Termination in Full Conduit	29
Figure 2.12: Shield Termination in Partial Conduit	29
2.8 The Isolator Module	30
Figure 2.13: Isolating Two Wire Communications Loops	30
2.9 Module Addressing	30
2.10 M300 Monitor Module	31
2.11 M301 Monitor Module	31
2.12 M302 Monitor Module	32
Figure 2.14: NFPA Style B Initiating Device Circuit (M300)	33
Figure 2.15: NFPA Style D Initiating Device Circuit (M300)	34
Figure 2.16: NFPA Style B Initiating Device Circuit (M302)	35
Figure 2.17: NFPA Style D Initiating Device Circuit (M302)	36
2.13 The Control Module	37
Figure 2.18: The C304 Control Module (Alarm polarity shown)	37
Figure 2.19: The C304 Control Module (Form-C Relay)	38
Figure 2.20: NFPA Style Y Notification Appliance Circuit	39
2.14 The Addressable Manual Pull Station	40
Figure 2.21: Wiring Addressable Manual Pull Stations	40
2.15 Wiring Detectors	41
Figure 2.22: Wiring the Detector with Removable Plug-in Connector	41
2.16 Optional Modules	42
Figure 2.23: Optional Module Location	42
Figure 2.24: ABS-8RF	43
Figure 2.25: UDACT-F Mounting to MS-9200	43
Figure 2.26: External UDACT-F Mounting in ABS-8RF	44
Figure 2.27: ACM-8RF Relay Control Module	45
Figure 2.27: RTM-8F Option Module Installation	46
Figure 2.28: RTM-8F Relay Transmitter Module	47
2.17 Printer/PC Interface Module	48
Figure 2.29: Remote Printer and Computer Connections	48

# Table of Contents

III.	Programming/Read Status	49
	3.0 Initial Power-up	50
	3.1 Programming	51
	3.2 Program Change - Level One	52
	3.2.01 Clear	52
	3.2.02 Autoprogram	52
	3.2.03 Point Edit	56
	3.2.04 System Edit	57
	3.2.05 Password Change	58
	3.2.06 Load	59
	3.3 Program Change - Level Two	59
	3.3.01 Disable	60
	3.3.02 Clear History	60
	3.3.03 Walk Test	61
	3.3.04 Set Time/Date	62
	3.3.05 Check	62
IV.	Operating Instructions	63
	Figure 4.1: The MS-9200 Membrane Switch Panel	63
	4.0 Control Switches	63
	4.1 LED Indicators	64
	4.2 Normal Operation	64
	4.3 Trouble Operation	65
	4.4 Alarm Operation	66
	4.5 Supervisory Operation	67
	4.6 Notification Appliance Circuit (NAC) Operation	68
	4.7 Control-By-Event Operation	68
	4.8 Detector Functions	68
	4.9 Time Functions	68
	4.10 Coder Operation - Notification Appliance (Bell) Circuit 1 Only	68
	4.11 Presignal	69
	4.12 Special System Timers	69
	4.13 Style 6 Operation	70
	4.14 Read Status	70
Appendix A	Power Supply and Battery Calculations	72
Appendix B	Software Zones	76
Appendix C	LCD-40 Annunciator Wiring	83
Appendix D	AFM and LDM Series Annunciator Wiring	84
Appendix E	NFPA Standards Specific Requirements	88
Appendix F	Wire Requirements	93
Appendix G	Compatible Surge Suppressors	94
Appendix H	Screen Options Flowchart	95



**THE MS-9200 COMPLIES WITH THE FOLLOWING NFPA 72-1993 NATIONAL FIRE ALARM CODE STANDARDS:**

- Central Station Fire Alarm Systems (Automatic, Manual, and Waterflow) Protected Premises Unit (requires UDACT-F).
- Local (Automatic, Manual, Waterflow and Sprinkler Supervisory) Fire Alarm Systems.
- Auxiliary (Automatic, Manual, and Waterflow) Fire Alarm Systems (requires RTM-8F).
- Remote Station (Automatic, Manual, and Waterflow) Fire Alarm Systems (Requires RTM-8F or UDACT-F).
- Proprietary (Automatic, Manual, and Waterflow) Fire Alarm Systems (Protected Premises Unit).
- Automatic Fire Detectors.
- Installation, Maintenance, and Use of Notification Appliances for Fire Alarm Systems.
- Testing Procedures for Fire Alarm Systems.

**IN ADDITION TO THE ABOVE, THE INSTALLER SHOULD BE FAMILIAR WITH THE FOLLOWING DOCUMENTS AND STANDARDS:**



**Underwriters Laboratories:**

- UL 38 Manually Actuated Signaling Boxes
- UL 217 Smoke Detectors, Single and Multiple Station
- UL 228 Door Closers - Holders for Fire Protective Signaling Systems
- UL 268 Smoke Detectors for Fire Protective Signaling Systems
- UL 268A Smoke Detectors for Duct Applications
- UL 346 Waterflow Indicators for Fire Protective Signaling Systems
- UL 464 Audible Signaling Appliances
- UL 521 Heat Detectors for Fire Protective Signaling Systems
- UL 864 Standard for Control Units for Fire Protective Signaling Systems
- UL 1481 Power Supplies for Fire Protective Signaling Systems
- UL 1971 Visual Signaling Appliances
- UL 1076 Proprietary Burglar Alarm Systems



**UNDERWRITERS LABORATORIES OF CANADA (ULC) LISTED**

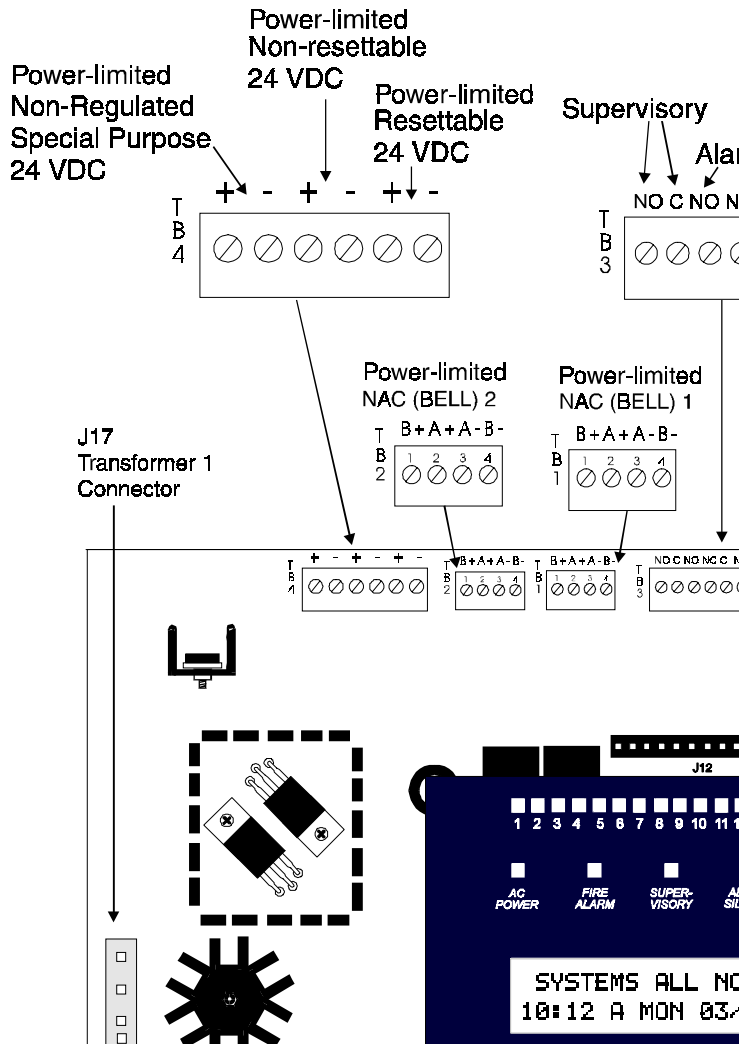
Standard CAN/ULC-S527-M87

**OTHER:**

- EIA-485 and EIA-232 Serial Interface Standards
- NEC Article 300 Wiring Methods
- NEC Article 760 Fire Protective Signaling Systems
- Applicable Local and State Building Codes
- Requirements of the Local Authority Having Jurisdiction

**FIRE-LITE DOCUMENTS AND MANUALS RELATING TO THE MS-9200:**

Fire-Lite Device Compatibility Document	Document# 15384
Annunciator Modules	Document# 15390
AFM-16ATF and AFM-32AF Annunciators	Document# 15970
AFM-16AF Annunciator	Document# 15210
MS-5012 Communicator	Document# 15465
MS-9200 Off Line Programming Utility	Document# 15677
UDACT-F Universal Digital Alarm Communicator Transmitter	Document# 50049
FCPS-24FE Field Charger/Power Supply	Document# 50079
LDM Series Lamp Driver Modules	Document# 50055
LCD-40 Remote Fire Annunciator	Document# 50327
ACM-8RF Relay Control Module	Document# 50362



# I SYSTEM OVERVIEW

## 1.0 Description

The Fire•Lite MS-9200 is a compact, cost effective, addressable Fire Alarm Control Panel (FACP) with an extensive list of powerful features. The combination of Fire•Lite's 300 Series Addressable Devices and the MS-9200 Fire Alarm Control Panel offers the latest in Fire Protection Technology. The power supply and all electronics are contained on a single circuit board housed in an attractive metal cabinet, providing a complete fire control system for most applications. Optional modules, which plug into the main board, are available for special functions. Accessories available include LED, graphic and LCD annunciators, digital communicator, local downloading software and remote power expansion.

## 1.1 Features

- Single standard SLC loop, meets NFPA Style 4, 6 and 7 requirements
- 198 addressable device capacity (99 detectors and 99 monitor/control modules)
- 56 software zones
- Two main board Notification Appliance (Bell) Circuits expandable via control modules
- Optional RTM-8F eight zone relay module with local energy/reverse polarity transmitter
- Optional ACM-8RF Relay Control Module
- Optional Printer/PC Interface Module
- 3.6 amps system power expandable to 6.6 amps
- 3.0 amps NAC power expandable to 6.0 amps
- 40 character LCD display, backlit
- Real time clock/calendar
- History file with 500-event capacity
- Advanced Fire Technology Features:
  - ✓ Automatic device type-code verification
  - ✓ Auto detector test
  - ✓ Maintenance alert
  - ✓ Point trouble identification
- Waterflow (non-silenceable) selection per module point
- Supervisory selection per point with separate system LED
- System Alarm Verification selection
- Walk Test, with report of two devices set to same address
- Presignal per NFPA 72
- Annunciators
  - ✓ AFM LED Zone Annunciator Series
  - ✓ LDM Graphic Annunciator Series
  - ✓ LCD-40 Liquid Crystal Point Display
- Silence inhibit timer option
- Auto silence timer option
- Continuous/March time/Temporal or California code for main board Notification Appliance (bell) Circuits
- Remote ACK/Silence/Reset/Drill via M300, M301 modules, AFM annunciators or LCD-40 Remote Fire Annunciator
- Auto-Program (learn mode) reduces installation time
- Password and key-protected nonvolatile memory
- Password is user programmable
- Fully programmable from panel keyboard
- Programmable from an off-line PC
- Rapid poll algorithm for manual stations (U.S. Patent Pending)
- SLC operates up to 10,000 ft. (or 1,000 ft. with untwisted, unshielded wire) U.S. Patent # 5,210,523
- Uses Fire•Lite 300 Series Addressable Devices:

<input type="checkbox"/> CP300	Ionization Smoke Detector
<input type="checkbox"/> SD300	Photoelectric Smoke Detector
<input type="checkbox"/> SD300T	Photoelectric Smoke Detector with 135° Thermal Detection
<input type="checkbox"/> C304	Control Module
<input type="checkbox"/> M300	Monitor Module
<input type="checkbox"/> M301	Miniature Monitor Module
<input type="checkbox"/> M302	2-Wire Detector Monitor Module
<input type="checkbox"/> I300	Isolator Module
- All 300 Series devices (except I300) feature decade code wheels
- 300 Series addressable smoke detectors feature a plug-in wiring connector for ease-of-installation and maintenance
- UDACT-F Digital Communicator, reports up to 56 zones or 198 points (all 300 Series devices) to a UL Listed Central Station

## 1.2 Specifications

### AC POWER - TB8

240 VAC, 50 Hz, 1.2 amps

Wire size: minimum #14 AWG with 600V insulation

### BATTERY (LEAD ACID ONLY) - J3

Maximum Charging Circuit: Normal Flat Charge—27.6V @ .8 amp.

Maximum Battery Capacity: 17 AH.

- 1) Up to 7 AH batteries can be housed in the MS-9200 enclosure.
- 2) 12 to 17 AH batteries require the Fire•Lite BB-17F or similar UL listed battery cabinet.
- 3) 20 to 55 AH batteries require the Fire•Lite R45-24E charger for housing and charging the batteries.

### COMMUNICATION LOOP - TB6

15 VDC nominal, 27.6 volts DC max. Maximum length is 10,000 ft. total twisted pair length. Maximum loop current is 250mA (Max short circuit) or 100 mA (normal). Maximum loop resistance is 40 ohms. SLC is supervised and power-limited.

*Note: The Communication Loop may leave the protected premises provided an approved surge suppressor is use (refer to Table G-1 in Appendix).*

### NOTIFICATION APPLIANCE CIRCUITS - TB1 & TB2

Non-regulated special purpose power

Power-limited circuitry

Maximum Voltage Drop in wiring: 2.0V

Operating Voltage Range: 18V to 30V

Current for all external devices: 3.0 amperes expandable to 6.0 amperes<sup>2</sup>.

Current Limit: Fuseless, electronic, power-limiting circuitry.

Max. signaling current/circuit: 2.50 amps

End-of-line resistor: 4.7K $\Omega$ , 1/2-Watt (part # 71252 UL listed) for Notification Appliance Circuits

### ALARM, TROUBLE, AND SUPERVISORY RELAYS - TB3

Contact rating: 2.0 amps @ 30 VDC (resistive), 0.5 amps @ 30 VAC (resistive)

Alarm and Trouble: Form-C Supervisory: Form-A

Refer to Figure 2.2 for information on power-limited wiring for relay circuits.

### FOUR-WIRE SMOKE DETECTOR POWER (24VDC nominal) - TB4 TERMINALS 5 (+) & 6 (-)

Max. ripple voltage: 10 mV<sub>RMS</sub> Max. standby current: 50 mA

Up to 300 mA is available for powering 4-wire smoke detectors <sup>1,2,3</sup>.

Power-limited circuit

### NONRESETTABLE REGULATED 24V POWER (24VDC nominal)—TB4 TERMINALS 3 (+) & 4 (-)

Max. ripple voltage: 10 mV<sub>RMS</sub> Max. standby current: 150 mA

Total DC current available from this output is up to 300 mA <sup>1,2,3</sup>

Power-limited circuit

### NON-REGULATED SPECIAL PURPOSE 24V POWER—TB4 TERMINALS 1 (+) & 2 (-)

Operating voltage range: 18V to 30V

Total DC current available for powering external devices is 2.5 amps <sup>2</sup>

This power is not recommended for AFM, LDM or LCD-40 annunciators

Power-limited circuit

### NOTES:

1. For power supply calculations, refer to Appendix A.
2. Total current for special purpose power, nonresettable power, four-wire smoke power, and two Notification Appliance Circuits *must not exceed 6.0 amperes*. Total external system current in excess of 3.6 amperes requires XRM-24E Transformer and 12AH or 17AH batteries, not 7.0 AH.
3. Total current for resettable 4-wire smoke power and non-resettable power must not exceed 600mA.



## 1.3 Controls and Indicators

### LCDDISPLAY

The MS-9200 uses a 40 character (2 lines X 20 characters), high viewing angle, LCD display, with a character height of 3/16". The display includes a long-life LED backlight that remains illuminated. If AC power is lost and the system is not in alarm, the LED backlight will turn off to conserve power.



### LED INDICATORS

- AC POWER (green)
- FIRE ALARM (red)
- SUPERVISORY (yellow)
- ALARM SILENCE (yellow)
- SYSTEM TROUBLE (yellow)

### MEMBRANE PANEL

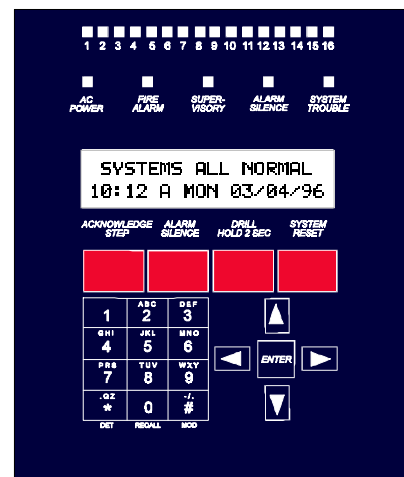
Mounted on the system board, the membrane switch panel includes a window for the LCD display and 5 system status LEDs. The membrane panel, which is visible with the cabinet door closed, has 21 keys, including a 12 key alphanumeric pad, similar to a telephone keypad.

Function switches:

- ACKNOWLEDGE/STEP
- ALARM SILENCE
- DRILL
- SYSTEM RESET (lamp test)

Service/program switches:

- Keypad with twelve Keys labeled 1-9
- \* (Detector) Key
- #(Module) Key
- 0 (Recall) Key
- Four cursor Keys (UP, DOWN, RIGHT, LEFT)
- ENTER Key



### LOCAL SOUNDER

A piezo sounder provides separate and distinct sounds for alarm, trouble and supervisory conditions.

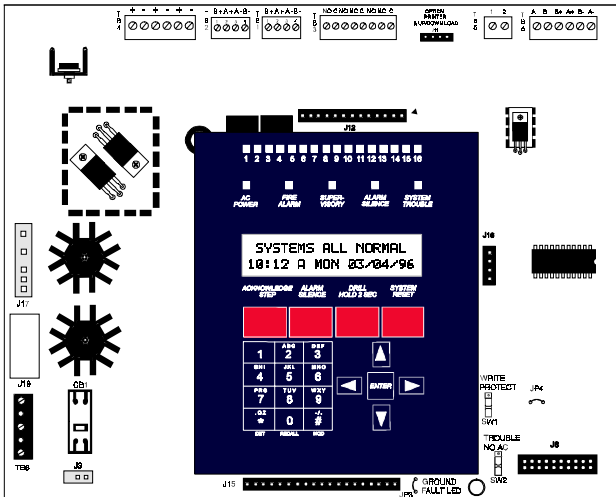
### NOTIFICATION APPLIANCE (BELL) CIRCUITS

Two NACs configurable for Style Y (Class B) or Style Z (Class A) with various programmable features.

### RELAYS

Three dry contact relays for System Alarm, System Trouble, and Supervisory. Contacts are rated 2A at 30VDC (resistive) and 0.5 amps at 30VAC (resistive).

# 1.4 Components



## MAIN CIRCUIT BOARD

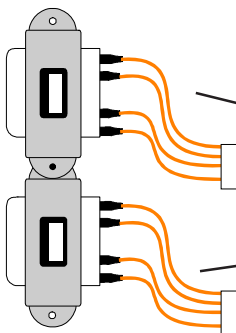
The main circuit board contains the system's CPU, power supply, other primary components and wiring interface connectors. Optional modules plug-in and are mounted to the main circuit board. The circuit board is delivered pre-mounted in the MS-9200 cabinet.

## CABINET

The MS-9200 cabinet is red with an attractive navy blue front overlay. The backbox measures 15" x 14.5" x 2.625" and provides space for two batteries (up to 7 amp-hours). Ample knockouts are provided for system wiring. Also available is an optional dress panel, DP-9200, which mounts to the inside of the cabinet (required and included on the ULC version). The dress panel must be installed to meet FM requirements (refer to Section 1.6).



Standard



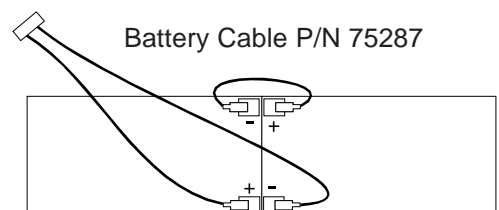
## TRANSFORMER ASSEMBLY

One 100VA transformer is provided standard with the panel. (3.6 Amps max.)

An optional 100VA transformer (XRM-24E) is available to provide maximum accessory power. (6.6 Amps max.)

## BATTERIES

The MS-9200 cabinet provides space for two 7 Amp-Hour (AH) batteries. 12AH to 17AH batteries require use of the Fire•Lite BB-17F or similar UL listed battery cabinet. 20 to 55 AH batteries can also be connected to the system, however, a Fire•Lite R45-24E charger is necessary for housing and charging these batteries. Batteries must be ordered separately.



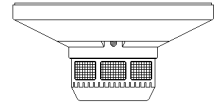
## Addressable Devices: 300 Series Detectors

Fire•Lite's new 300 Series Addressable Detectors consist of the SD300 Photoelectric, SD300T Photoelectric with thermal sensor and the CP300 Ionization smoke detectors. The detectors communicate with the main circuit board CPU via an SLC loop. The MS-9200 CPU determines the alarm, maintenance, or normal status of each device. Each detector responds to an address that is manually set via built-in rotary decimal switches. Each detector head has a removable plug-in connector for ease of wiring and maintenance (or service), as well as a single LED and test connections. Detector Specifications follow:

Voltage Range:	15 - 28 Volts DC Peak	Diameter:	5.0 inches (12.7 cm)
Standby Current:	150uA @ 24 VDC	Height:	3.0 inches (7.6 cm)
LED Current:	7mA @ 24 VDC (latched 'ON')	Temperature:	0° to 49° C (32° to 120° F)
Loop Resistance:	40 ohms Maximum	Rel. Humidity:	10% - 93% Non-condensing
Air Velocity:	CP300 = 1,500 Ft/Minute (7.6m/S) Max.	SD300 = 3,000 Ft/Minute (15 m/S) Max.	

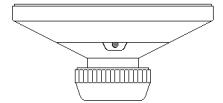
### SD300, SD300T

The **SD300 is an Addressable Photoelectric Smoke Detector** which provides smoke sensing utilizing optical sense technology. The detector sends a unique 'type' code to aid the automatic programming feature in the control panel. The **SD300T** includes a 135° F fixed thermal sensor.



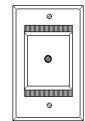
### CP300

The **CP300 is an Addressable Ionization Smoke Detector** which measures the level of combustion products in its chamber using the 'ionization principle'. The detector sends a unique 'type' code to aid the automatic programming feature in the control panel.



### RA400Z

The **RA400Z is a Remote Single LED Annunciator** that can be wired directly to an addressable detector for annunciation of that detector's alarm status.

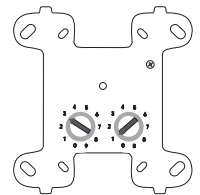


## Addressable Devices: 300 Series Modules

The C304 Control Module plus the M300, M301 and M302 Monitor Modules provide an interface between the MS-9200 and conventional initiating devices and notification appliances. All modules respond to an address that is set by the installer via two built-in rotary decimal switches. A flashing LED indicates power is applied to the modules (except for M301). A thermoplastic cover is provided with all modules except the M301, for mounting to a 4-inch square mounting box.

### M300

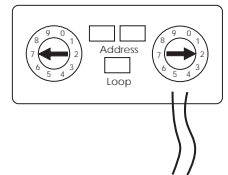
The M300 is an **Addressable Monitor Module** that can be used to monitor conventional normally-open contact alarm initiating devices, such as manual pull stations, 4-wire smoke detectors, heat detectors, waterflow, and supervisory devices. The supervised circuit can be wired NFPA Style B (Class B) or Style D (Class A). *The M300 module will not support 2-wire smoke detectors.* The M300 modules can be tested with a test magnet available from Fire•Lite (M02-04-00). The magnet test checks the module electronics and connections to the control panel. The module mounts to a 4-inch square electrical box with a minimum depth of 2-1/8".



M300 and M302

### M301

The M301 is an **Addressable Monitor Module** that is a miniature version of the M300. It connects with wire pigtails [Style B (Class B) only], and may be mounted directly in the electrical box of the device being monitored. Dimensions of 2.75" L x 1.30" W x 0.50" D, allow for mounting in existing single-gang electrical boxes, the device being monitored, or similar locations.

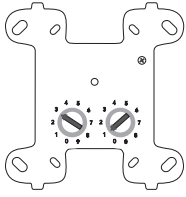


M301

### M302

The M302 is an **Addressable Monitor Module** that can be used to interface and monitor conventional 2-wire smoke detectors. All 2-wire detectors being monitored must be UL compatible with the module (refer to the Fire•Lite Compatibility Document). The supervised circuit can be wired NFPA Style B or D. The M302 modules can be tested with a test magnet available from Fire•Lite (P/N M02-04-00). Separate regulated switched 24 VDC power is required. The module mounts to a 4-inch square electrical box with a minimum depth of 2-1/8".

## Addressable Devices: Modules (continued)



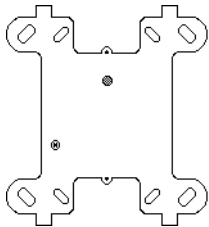
### C304

The C304 is an **Addressable Control Module** that can be used as a Notification Appliance or Speaker Circuit for powering and supervising compatible, UL listed Notification Appliances. The module's supervised circuit can be wired NFPA Style W, X, Y or Z. A 47 K ELR is provided. By breaking two built-in tabs, the C304 can be employed as a Form-C control relay. The module mounts to a 4-inch square electrical box with a minimum depth of 2-1/8".



### BG-10LX

The BG-10LX is an **Addressable Manual Pull Station** featuring a key-lock reset. The pull station responds to an address set by the installer using the built-in rotary decimal switches on the pull station. The Manual Pull Station includes a Fire•Lite key.



### I300

The **Loop Isolator Module** (I300) is an automatic switch which opens the circuit voltage to the SLC Loop branch(es) whenever a wire-to-wire short circuit is detected on that loop. The remainder of the Communications Loop leading up to the I300 will continue to operate, unaffected by the short. The isolator module has four terminal connections, allowing input and output SLC connections. The isolator is bi-directional, meaning that it can detect a fault condition between the input SLC terminals, or output SLC terminals. The I300 is required to meet NFPA Style 7 requirements.

## Addressable Device Accessories

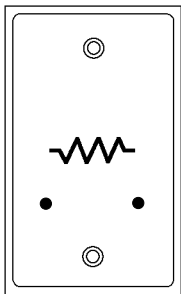


### E.O.L. RESISTOR FIRE•LITE P/NR-47K

The **47K End-Of-Line Resistor Assembly** is used to supervise the M300 Monitor and C304 Control Module circuits. The resistor is included with each M300 and C304 module.



A UL listed **End-Of-Line Power Supervision Relay** is used to supervise the power to 4-wire smoke detectors and Notification Appliances.



### N-ELR

The **N-ELR** is a single End-of-Line Resistor plate which is required for use in Canada. An ELR, which is supplied with each module and fire alarm control panel, must be mounted to the plate. Resistors mounted to the N-ELR plate can be used for the supervision of an M300 and M301 Monitor Module and C304 Control Module circuit.

## 1.5 Optional Interface Modules

The MS-9200 main circuit board includes option module connectors, located on the right side of the board. Available option modules include:

### ACM-8RF RELAY CONTROL MODULE

The ACM-8RF Relay Control Module contains eight high current (5 amp) Form-C relays. The module interfaces to host fire alarm control panels which employ an EIA-485 communications bus. ACM-8RF modules may be connected to the EIA-485 bus up to 6,000 feet away from the host control panel. Power-limited, regulated, nonresettable power must be supplied by the host FACP or a UL listed power supply such as the FCPS-24F. (See Figure 2.27 for wiring details).

### RTM-8F RELAY MODULE

The Relay/Transmitter Module (RTM-8F) plugs into connector J6 and mounts on the bottom right side of the MS-9200 main circuit board. When the module is installed, jumper JP4 must be cut in order to provide module placement supervision. The RTM-8F provides eight Form-C relays (5 Amp contacts). These relays track software zones 1 through 8. The Relay/Transmitter Module also provides Municipal Box or Remote Station transmitters. An MS-9200 equipped with an RTM-8F meets NFPA 72 (Auxiliary) and NFPA 72 (Remote Station) requirements. In remote station applications, the RTM-8F can be configured to transmit alarm only or alarm and trouble. Disable switches and indicators are provided on the module. (See Figure 2.27 and Figure 2.28.)

### PIM-24 PRINTER/PC INTERFACE MODULE

The Printer/PC Interface Module may be used to permanently connect a printer to the MS-9200 for the purpose of printing a history report, walktest file or program listing. Printers require 240 VAC, 50Hz primary power. Connect the PIM-24 module (with cable P/N 75267) to the serial EIA-232 port on the printer. The module mounts to the J11 connector on the MS-9200 main circuit board. The PIM-24 is also used to connect a computer for Upload/Download of programming data. Refer to the Off Line Programming Utility Manual Document# 15677, for programming information. See Figure 2.29 for information on connections and System Edit in the Programming/Read Status Section of this manual for information on programming the MS-9200 for use with a printer or PC. (This option is not available simultaneously with use of the DIM-485/LCD-40).

### PK-9200 KIT FOR LOCAL DOWNLOADING

The PK-9200 Programming Utility can be used to program an MS-9200 directly from most IBM PC/XT/AT or compatible computers, including laptops and portables, equipped with a serial port. MS-9200 program files can also be created and stored on the PC, then downloaded to the panel. The PK-9200 Kit includes the MS-9200 Programming Utility software on 3-1/2" floppy disk P/N 75298, the Instruction Manual P/N 15677 and the PIM-24 (Printer/PC Interface Module with cable P/N 75267 and DB9F/25 connectors P/N 46029).

### UDACT-F UNIVERSAL DIGITAL ALARM COMMUNICATOR TRANSMITTER

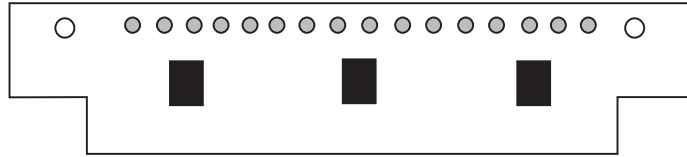
The UDACT-F transmits system status to UL Listed Central Station Receivers via the public switched telephone network. The UDACT-F is compact in size and may be mounted inside the host control panel or may mount externally in a separate cabinet. EIA-485 annunciator communications bus and regulated 24 volt connections are required. The UDACT-F transmits 198 points or 56 zones when connected to the MS-9200. The MS-9200 requires firmware P/N 73580 or greater in order to be compatible with the UDACT-F. (Refer to Figures 2.25 and 2.26 for wiring details and System Edit in the Programming/Read Status Section of this manual for information on programming the MS-9200 for use with the UDACT-F).

### DIM-485 DISPLAY INTERFACE MODULE

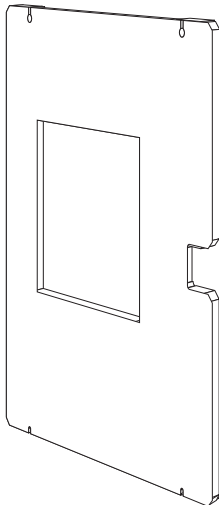
The Display Interface Module (DIM-485) is required to connect an LCD-40 Remote Fire Annunciator to the MS-9200 FACP. The DIM-485 plugs into connector J11 on the top right side of the MS-9200 main circuit board. Refer to Appendix C for wiring details and System Edit in the Programming/Read Status Section of this manual for information on programming the MS-9200 for use with the LCD-40. (This option is not available simultaneously with use of the PIM-24).

## ZDM-16F 16 ZONE LED MODULE

The ZDM-16F mounts to the back of the membrane switch panel with 2 screws and connects by cable to J12 on the MS-9200 main circuit board. Sixteen individual red LEDs on the module annunciate alarms for the first sixteen software zones.



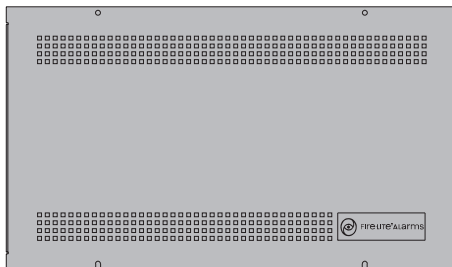
## 1.6 Accessories



### DRESS PANEL

A red dead-front dress panel (DP-9200) is available as an option (required for Canadian installations). The dress panel restricts access to the system wiring while allowing access to the membrane switch panel.

*Note: The MS-9200 Addressable Fire Control Panel installed with the DP-9200 dress panel, has received Factory Mutual (FM) approval. It is important to note that FM approval is contingent on the proper installation of the DP-9200 dress panel.*

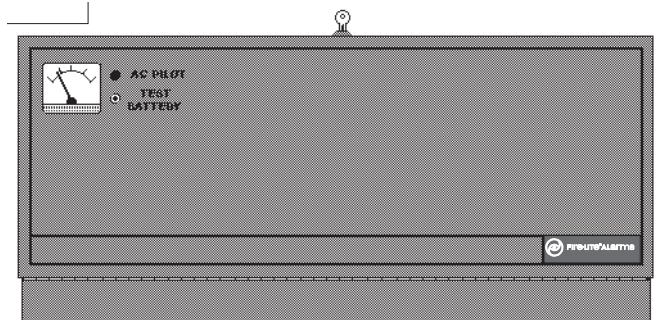


### BATTERY BOX

The BB-17F battery box may be used to house two 12AH or 17AH batteries. The battery box mounts directly below the MS-9200 cabinet. The box is red in color and is provided with knockouts.

## Accessories: R45-24E Remote Battery Charger

The **Fire•Lite Remote Battery Charger (R45-24E)** is capable of charging 20-55 amp-hour batteries. This unit is required in a system using 25 amp hour or larger batteries. The batteries and charger are housed in the R45-24E cabinet, which can be mounted up to 20 feet away from the control panel. To determine the battery size needed in a particular system, see the Standby Power Requirements in Appendix A.



### CONNECTING THE PRIMARY POWER SOURCE

With the breaker at the main power distribution panel turned off, connect the primary Hot line to Terminal 1 on the R45-24E and the primary Neutral line to Terminal 2. All connections between the MS-9200 and the R45-24E must be made in conduit, using #14 AWG wire. Do not route 240 VAC wiring in the same conduit as other control panel circuits. Leave the main power breaker off until installation of the entire system is complete.

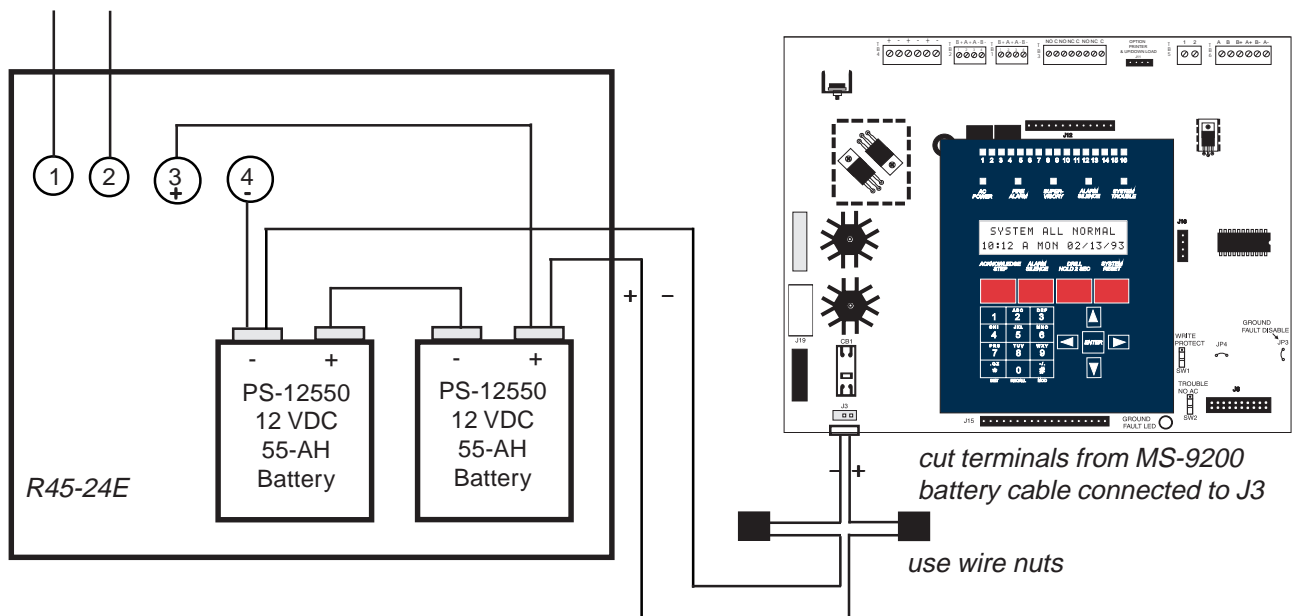
### CONNECTING THE SECONDARY POWER SOURCE

Do not apply AC power or batteries until the system is completely wired and ready for testing. Refer to the Wiring Diagram and Instructions for the R45-24E Charger (DWG. No. 1977-41 packaged with the R45-24E) for additional information.

## Remote Battery Charger Connection

240 VAC, 50 Hz,  
0.5 Amp Primary Power  
Source  
Hot Neutral

**24 VDC (supervised).** The maximum charge current for standby batteries is 2 amps (fast charge) or 20mA (trickle charge). Use #14 AWG wire in conduit (20 feet or less).

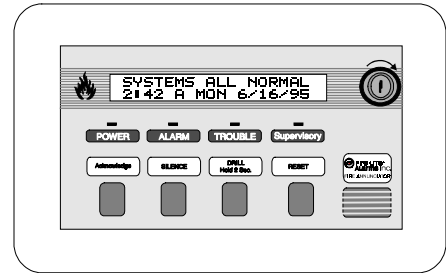


Note: Apply primary AC power to MS-9200 via standard transformer or with additional option transformer XRM-24E. See Appendix A.

## Accessories: LCD Point Annunciator - LCD-40 Remote Fire Annunciator

(refer to Appendix C for detailed wiring requirements and System Edit in the Programming/Read Status Section of this manual for information on programming the MS-9200 for annunciator use)

The LCD-40 is a compact, attractive, 40-character backlit LCD fire annunciator that is capable of displaying English-language text. It mimics the display on the MS-9200 main control circuit board and will annunciate device type, point alarm, trouble or supervisory condition, zone assignment plus any custom alpha labels programmed into the control panel. It also provides system status LEDs to display Power, Alarm, Trouble and Supervisory conditions. Additionally, the LCD-40 is capable of performing critical system functions such as acknowledge, silence, reset and drill, remotely from the host control panel.



Communication between the control panel and the LCD-40 is accomplished over a serial interface employing the EIA-485 communication standard (DIM-485 option module required). Up to 32 LCD-40s may be connected to the EIA-485 circuit. The annunciator may be powered from the host FACP or a remote UL listed, filtered, regulated power supply such as the Fire•Lite FCPS-24FE.

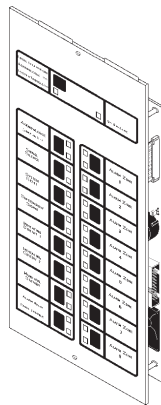
## Accessories: LED Zone Type - AFM Series Annunciators

(refer to Appendix D for detailed wiring requirements and System Edit in the Programming/Read Status Section of this manual for information on programming the MS-9200 for annunciator use)

The AFM Series Annunciators remotely display system status. The AFM/AEM-16AT annunciators display zone alarm and trouble status. In addition, they provide remote ACKNOWLEDGE, SILENCE, RESET and DRILL functions. The AFM/AEM-32 annunciators display zone alarm status only and provide no remote system switch functions. For more detailed information, refer to the appropriate AFM Annunciator manual.

### AFM-16ATX

The Annunciator Fixed Module-16ATX contains 16 red alarm and 16 yellow trouble LEDs, a system trouble LED, an ON LINE/POWER LED, and a local piezo sounder with switches for MS-9200 ACKNOWLEDGE, SILENCE, RESET, and DRILL. The AFM-16ATX is fixed at address '1' and will accept up to 3 AEM-16ATF Expanders.

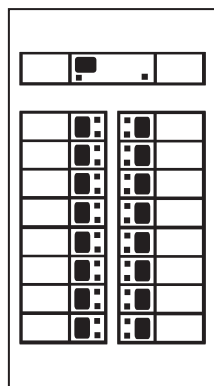


### AEM-16ATF

The Annunciator Expander Module-16ATF connects to the AFM-16ATX and adds 16 sets of red alarm LEDs and yellow trouble LEDs. Three AEM-16ATFs may be added to an AFM-16ATX.

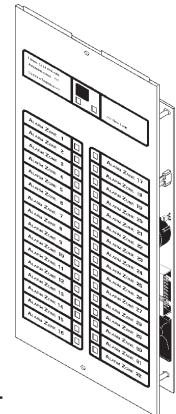
### AFM-16ATF

The Annunciator Fixed Module-16ATF contains 16 red alarm and 16 yellow trouble LEDs, a system trouble LED, an ON LINE/POWER LED, and a local piezo sounder with switches for MS-9200 ACKNOWLEDGE, SILENCE, RESET, and DRILL. The AFM-16ATF is fixed at address '1' and communication is via the EIA-485 data line.



### THE AFM-32AX

The Annunciator Fixed Module-32AX contains 32 red alarm LEDs, a system trouble LED, an ON LINE/POWER LED, and a local piezo sounder with a local Silence/Acknowledge switch. The AFM-32AX is fixed at address "1," and will accept one AEM-32AF expander.

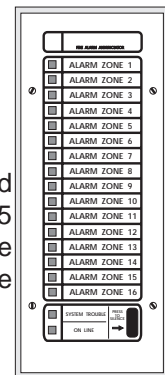


### AEM-32AF

The Annunciator Expander Module-32AF connects to the AFM-32AX and adds 32 red alarm LEDs. The AEM-32AF is identical in frontal appearance to the AFM-32AX. Only one expander module is allowed.

### AFM-16AF

The Annunciator Fixed Module-16AF has 16 red alarm LEDs. Multiple annunciators may be used by setting all annunciators to Receive Only, except the last AFM-16AF in line. Each annunciator's address is internally fixed at '1', and communication is via the EIA-485 data line. The Local Silence/Acknowledge switch functions as local lamp test and silence for annunciator piezo. LEDs include On Line and System Trouble indicators.



### AFM-32AF

The AFM-32AF is similar to the AFM-16AF except it has 32 red alarm LEDs for annunciating up to 32 points.



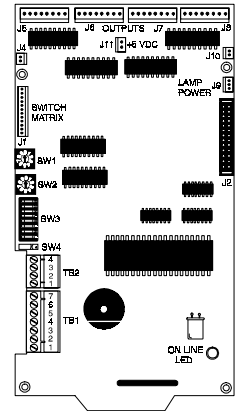
## Accessories: Graphic Annunciator Driver - LDM Series Lamp Driver Modules

(refer to Appendix D for detailed wiring requirements and System Edit in the Programming/Read Status Section of this manual for information on programming the MS-9200 for annunciator use)

The LDM Series Lamp Driver Modules, which consist of the LDM-32F master and LDM-E32F expander modules, are used to provide an interface to a custom graphic LED annunciator. The master module provides power and control for a maximum of three expander modules. The LDM-32F and LDM-E32F have output connectors which are used to drive lamps or LEDs and input connectors which are used for remote switch functions. Refer to the LDM Series Lamp Driver Modules Manual for a complete description.

### The LDM-32F

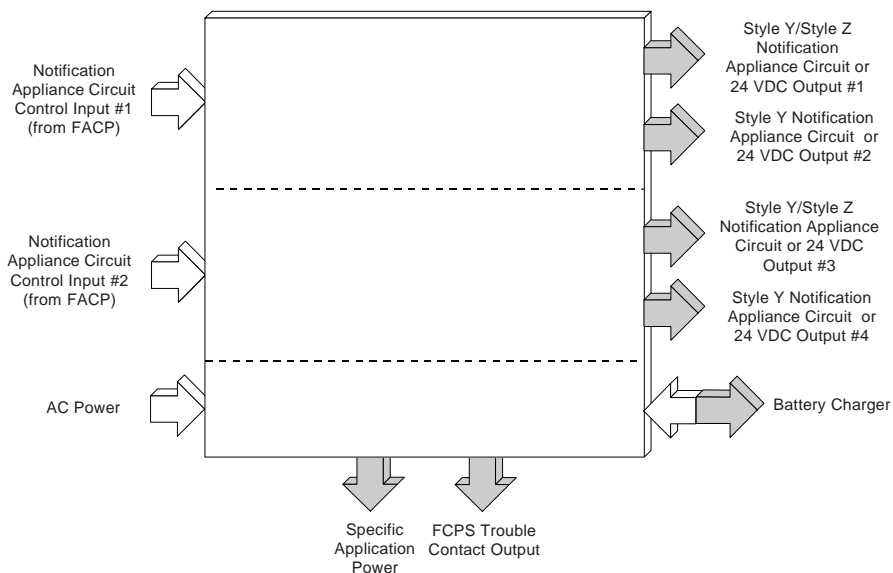
The Lamp Driver Module LDM-32F has 32 alarm lamp/LED driver outputs which sink current to system common (-) on activation. A single positive (+) voltage is required to supply total operating power for all lamps or LEDs when all drivers are activated. The LDM-32F provides a separate driver for system trouble and inputs for a local lamp test switch. A maximum of 16 external control switches may be wired to the LDM-32F. DIP switch SW3 is used to enable or disable the onboard piezo, enable remote switch functions, select a flashing LED function for new alarms and troubles, and other functions. Switch SW4 is used to configure the module to annunciate 32 alarms or 16 alarms and 16 troubles. A green ON-LINE LED flashes to indicate ongoing communications with the host FACP. One LDM-32F supports up to 3 LDM-E32F modules. The LDM-32F is supplied with 4 standoffs and screws for mounting to a CHS-4L chassis or custom backbox.



## Accessories: System Power Expansion - FCPS-24FE Remote Field Charger Power Supply

The FCPS-24FE is a compact, remote power supply with battery charger. This remote power supply consists of a filtered 24 VDC output that may be configured to drive up to four Notification Appliance Circuits [four Style Y (Class B) or two Style Z (Class A) and two Style Y (Class B)]. Alternately, the four Notification Appliance Circuits may be used as auxiliary regulated power configured for resettable or nonresettable operation.

The FCPS-24FE may be used in a number of different applications. It may be used as a remotely-mounted power supply and battery charger powering up to four, coded or non-coded, Notification Appliance Circuits. Alternately, any or all of these circuits may be used as 24 VDC output circuits capable of powering four-wire smoke detectors or any device that requires filtered power. These circuits may be configured as resettable or nonresettable outputs to expand FACP auxiliary system power.



One of the most common applications for the FCPS-24FE remote power supply utilizes the NAC expander mode. In this application, one or two Notification Appliance Circuits (NACs) are connected from the main FACP NAC output(s) to the remote power supply Control Input circuits. When these Control Input circuits activate (due to reverse polarity of the NAC output), the power supply will activate its corresponding outputs. NAC Control Input #1 controls power supply output circuits #1 and #2. NAC Control Input #2 controls output circuits #3 and #4.

During the inactive state, the remote power supply supervises its NAC field wiring for short and open circuits. If a fault is detected, the supply will enter a trouble condition and illuminate the corresponding NAC trouble LED (Output Circuits 1-4). However, once the Notification Appliance Circuits are activated, the supervision is disabled and the circuits are no longer supervised. Supervision of other power supply faults such as low battery, Earth Fault, AC loss and battery charger failure will continue and may be monitored via the independent trouble relay contact.

If a specific application requires that all four outputs activate at the same time, only one NAC control input from the FACP is necessary. For this application, the Notification Appliance Circuit from the FACP is wired into NAC Control Input #1 of the remote supply and then a pair of wires are connected from NAC Control Output #1 to NAC Control Input #2. Refer to the FCPS-24FE Installation, Operation and Application Manual for a complete description and examples of applications.

A C304 Control Module, which can be located up to 10,000 feet from the FACP, may be used to activate the FCPS power supply. The Control Module can be powered from the FCPS auxiliary 24 VDC power output (TB3 Terminals 8 & 9) and supervised by an EOL relay.

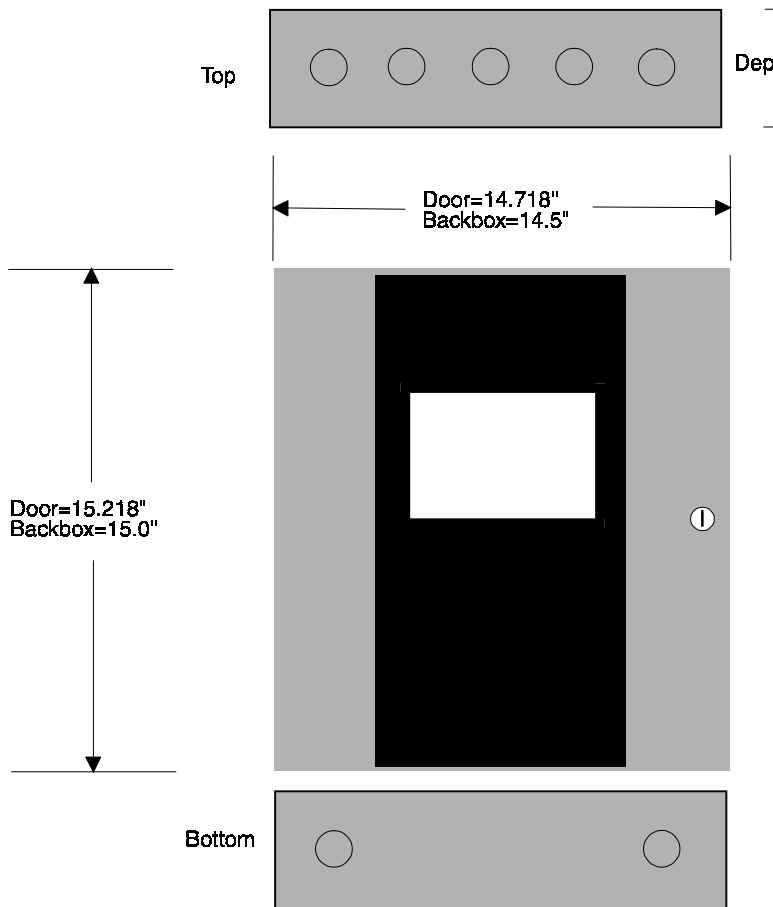
# II INSTALLATION

## 2.0 General

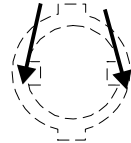
Carefully unpack the system and check for shipping damage. Mount the cabinet in a clean, dry, vibration-free area where extreme temperatures are not encountered. The area should be readily accessible with sufficient room to easily install and maintain the panel. Locate the top of the cabinet approximately five feet above the floor with the hinge mounting on the left. Determine the number of conductors required for the devices to be installed. Sufficient knockouts are provided for wiring convenience. Select the appropriate knockout(s) and pull the required conductors into the box. All wiring should be in accordance with the National and/or Local codes for fire alarm systems.

## 2.1 Cabinet Dimensions

### Surface Mount w/BB-17F Battery Box



To remove entire knockout, strike here.

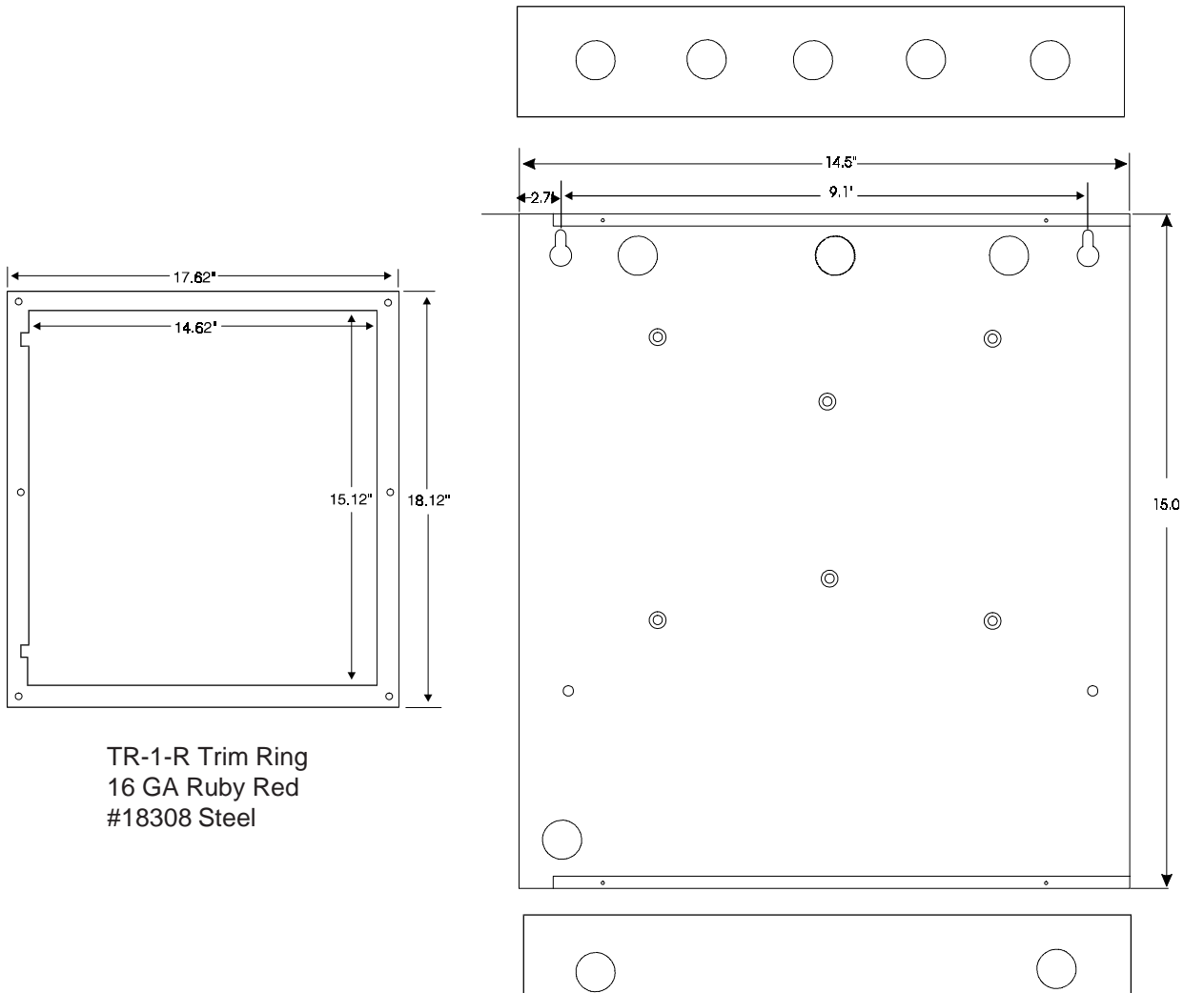


To remove inner knockout, strike here.



## 2.2 Backbox Mounting

- 1) Remove the main PC board assembly by unscrewing the four screws in the corners of the board. Two standoffs support the board in the center. Set the board aside in a safe, clean place. Avoid static discharge which may damage the board.
- 2) Mark and predrill holes for the top two keyhole mounting bolts using the dimensions shown.
- 3) Install two upper fasteners in the wall with the screw heads protruding.
- 4) Using the upper 'keyholes', mount the backbox over the two screws.
- 5) Mark and drill the lower two holes.
- 6) Complete backbox mounting by installing the remaining fasteners. Tighten all screws.
- 7) When the location is dry and free of construction dust, reinstall the main PC board.



## 2.3 Power

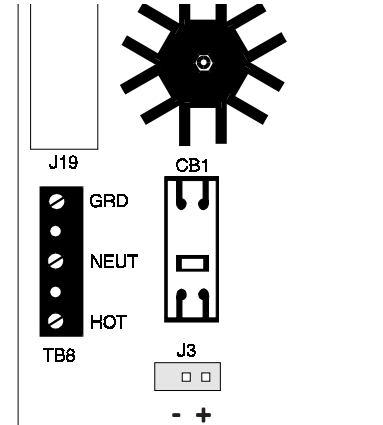
**CAUTION:** Several different sources of power can be connected to this panel. Disconnect all sources of power before servicing. The panel and associated equipment may be damaged by removing and/or inserting cards, modules, or interconnecting cables while this unit is energized.

### AC POWER/EARTH GROUND CONNECTIONS

Primary power required for this panel is 240 VAC, 50 Hz, 1.2 amperes. Overcurrent protection for this circuit must comply with Article 760 of the National Electrical Code (NEC) and/or local codes. Use #14 AWG or larger wire with 600 volt rating.

In order to comply with Compatibility Directive 89/336/EEC for European Communities (EU Requirements), a Ferrite Bead, P/N 29085, must be installed on the Mains for RF filtering. Refer to Document #50404 for details.

Connect one of the mounting screws for the system transformer to a known solid earth ground. This connection is vital for maintaining the control panel's immunity to unwanted transients generated by lightning and electrostatic discharge.



### BATTERY POWER

Observe polarity when connecting the battery. Connect the battery cable to J3 on the MS-9200 main circuit board using the plug-in connector provided. See Appendix A for calculation of the correct battery rating. **CAUTION:** Battery contains sulfuric acid which can cause severe burns to the skin and eyes, and can destroy fabrics. If contact is made with sulfuric acid, immediately flush the skin or eyes with water for 15 minutes and seek immediate medical attention.

**Figure 2.1: DC Power Output Connections**

*All DC power outputs are power-limited*

#### **Power-limited**

#### **Non-Regulated Special Purpose Power**

2.5 amps, 24 VDC power for Notification Appliance Circuits. TB4 Terminal 1 (+) and 2 (-). Note: This power is unsuitable for all EIA-485 annunciation devices.

#### **Power-limited**

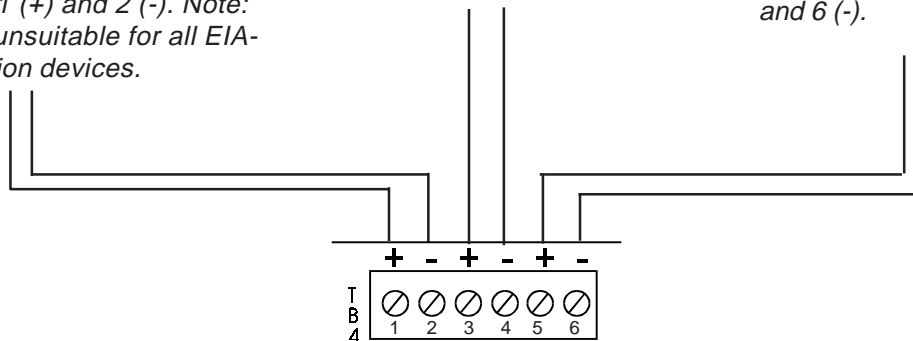
#### **Nonresettable Power**

300 mA, 24 VDC filtered, regulated, non-resettable power can be drawn from TB4 Terminals 3 (+) and 4 (-).

#### **Power-limited**

#### **Resettable Power**

300 mA, 24 VDC filtered, regulated, resettable power can be obtained from TB4 Terminals 5 (+) and 6 (-).

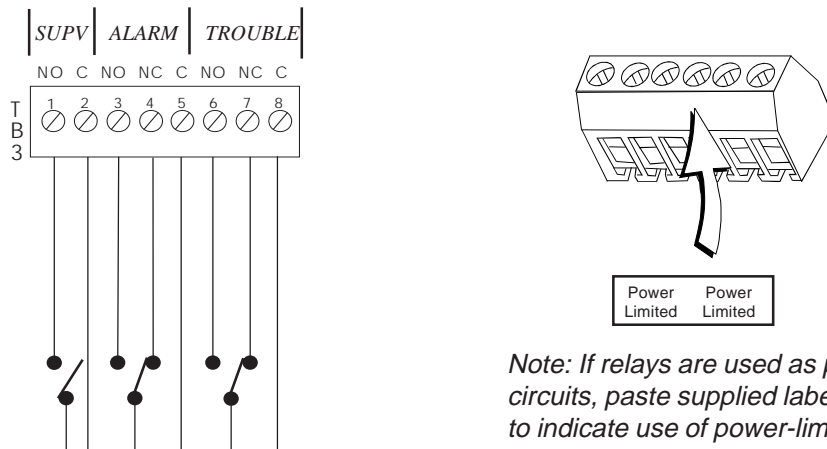


## 2.4 Standard Relays

The MS-9200 provides a set of Form-C alarm and a set of Form-C trouble contacts rated for 2.0 amps @ 30VDC (resistive). The panel also provides a Form-A supervisory contact rated for 2.0 amps @ 30VDC (resistive). Refer to Figure 2.4 for UL Power-limited wiring requirements.

**Figure 2.2: Relay Connections**

*Note: Relay connections may be power-limited or nonpower-limited, provided that 0.25" spacing is maintained between conductors of power-limited and nonpower-limited circuits.*



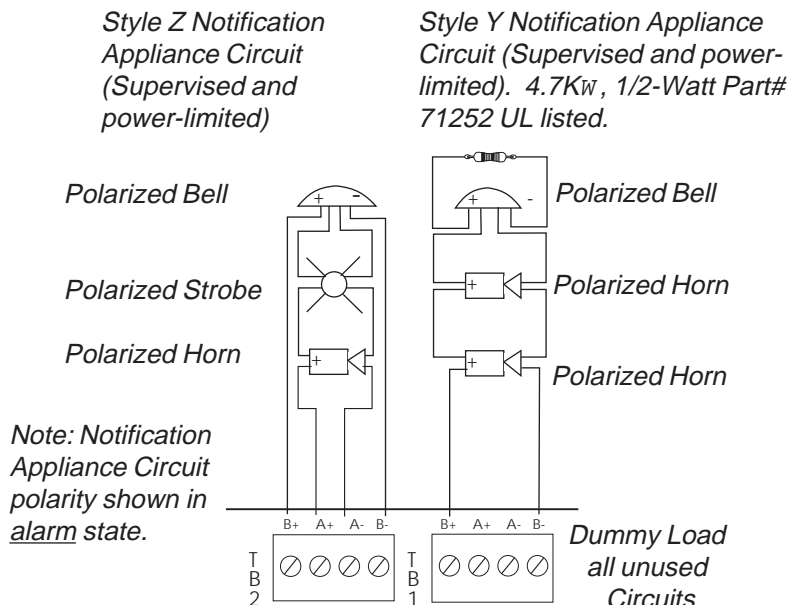
*Note: If relays are used as power-limited circuits, paste supplied label to terminal block to indicate use of power-limited wiring.*

## 2.5 Output Circuits

### NOTIFICATION APPLIANCE CIRCUITS

The MS-9200 provides two Notification Appliance (bell) Circuits (Style Y or Z). Each circuit is capable of 2.5 amps of current. Total current drawn from these as well as other DC power outputs cannot exceed 6.0 amps. Use UL listed 24 Volt notification appliances only. Circuits are supervised and power-limited. Refer to the Fire•Lite Device Compatibility Document for a listing of compatible notification appliances. The two Notification Appliance Circuits located on the main circuit board may be expanded via the Fire•Lite FCPS-24FE Field Charger/Power Supply. Surge protection for notification appliances may be provided by using one of the compatible surge suppressors listed in Table G-1 of the appendix.

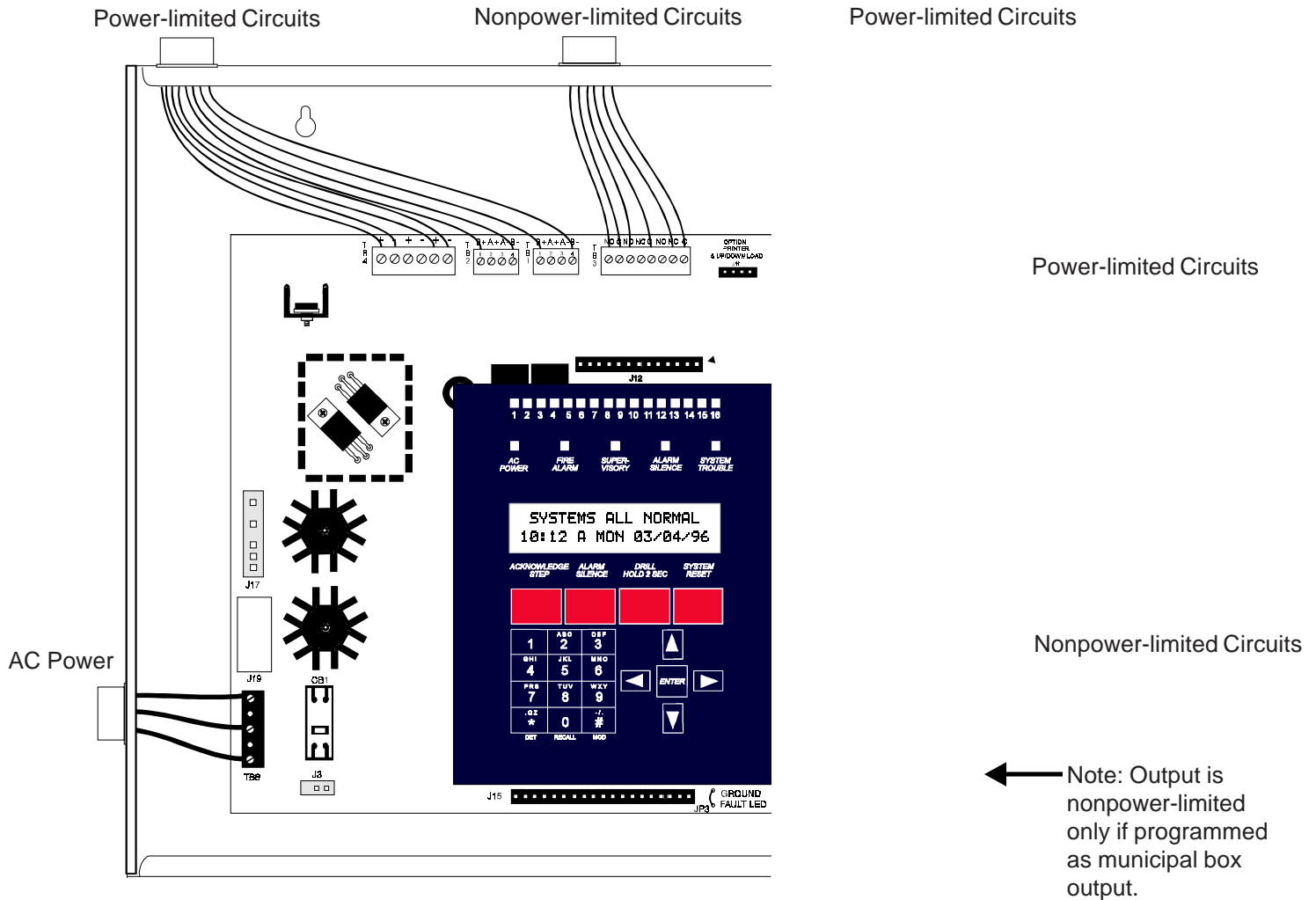
**Figure 2.3: Circuit Connections**



## 2.6 UL Power-limited Wiring Requirements

Power-limited and nonpower-limited circuit wiring must remain separated in the cabinet. All power-limited circuit wiring must remain at least 0.25" away from any nonpower-limited circuit wiring. Furthermore, all power-limited circuit wiring and nonpower-limited circuit wiring must enter and exit the cabinet through different knockouts and/or conduits. A typical wiring diagram for the MS-9200 is shown below.

**Figure 2.4: Typical Wiring Diagram for UL Power-limited Requirements**

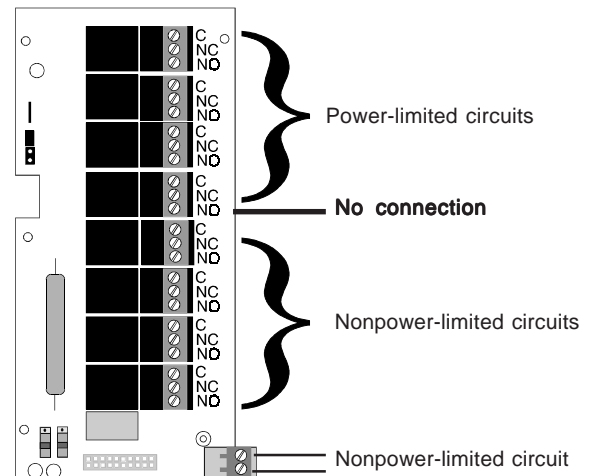


### 2.6.1 RTM-8F Wiring

Nonpower-limited and power-limited wiring must have a minimum distance of 0.25" wire to wire. If this module is used to drive nonpower-limited and power-limited circuits, follow the instructions below:

1. Skip a set of dry contacts to maintain the 0.25" required space between power-limited and nonpower-limited circuits.
2. If this module is needed to drive power-limited and nonpower-limited relays that are next to each other, make no connection to the Normally Open contact which separates the two groups of relays. Refer to the typical wiring diagram to the right.

Refer to Figure 2.29 for additional information on the RTM-8F Relay Transmitter Module.



## 2.7 Wiring the Signaling Line Circuit

The MS-9200 communicates with addressable initiating, monitor and control devices through a Signaling Line Circuit (SLC) Loop. This SLC loop can be wired to meet the requirements of NFPA Style 4 (see Figure 2.7), Style 6 (see Figure 2.8) or Style 7 (see Figure 2.9). Surge protection for the SLC Loop may be provided by using one of the compatible surge suppressors listed in Table G-1 of the Appendix. The SLC Loop is allowed to leave the building only with use of an approved surge suppressor (refer to Table G-1). Be certain to change the decade wheels on all detectors and modules from the factory '00' settings.

### ISOLATOR MODULES

Isolator Modules permit a zone of detectors and modules to be electrically 'isolated' from the remainder of the Communications Loop, allowing critical loop components to function in the event of a short circuit on the SLC Loop wiring (see Figures 2.7, 2.8 and 2.9). These are required to meet the requirements of NFPA Style 7.

### MONITOR MODULES

Addressable Monitor Modules allow the control panel to monitor entire circuits of conventional normally-open contacts, alarm initiating devices, manual pull stations, 4-wire smoke detectors, heat detectors, waterflow, supervisory devices (see Figures 2.14 and 2.15) and conventional detectors (see Figures 2.16 and 2.17). The BG-10LX is an addressable manual pull station which contains a miniature monitor module providing point annunciation (see Figures 2.7, 2.8 and 2.21).

### CONTROL MODULES

Through addressable Control Modules, the control panel can selectively activate Notification Appliance Circuits or Form-C output relays (see Figures 2.18 through 2.20).

### ADDRESSABLE DETECTORS

Through the Communications Loop, the MS-9200 communicates with addressable ionization, photoelectric, and photoelectric/thermal detectors (see Figure 2.22).

### DEVICE CAPACITY

The capacity of each MS-9200 includes up to 99 addressable detectors, and an additional combination of up to 99 addressable pull stations, control modules and monitor modules. In addition, the panel supports 2 Notification Appliance (Bell) Circuits.

Note: Refer to Appendix A and the installation drawings supplied with each loop device for rating and specification information.

**Table 2.1: Communications Loop Performance**

Single Open on Loop	Single Ground on Loop	Shorted Loop	Loop Shorted and Opened	Loop Shorted and Grounded	Loop Opened and Grounded	Communication Loss
Style 4 (2-wire) Loop Operation (meets NFPA 72 Style 4 requirements)						
Trouble <sup>1</sup>	Alarm Capability Trouble <sup>2</sup>	Trouble	Trouble	Trouble	Trouble	Trouble
Style 6 (4-wire) Loop Operation (meets NFPA 72 Style 6 requirements)						
Alarm Capability Trouble	Alarm Capability Trouble	Trouble	Trouble	Trouble	Alarm Capability Trouble	Trouble
Style 7 (4-wire) Loop Operation (meets NFPA 72 Style 7 requirements) <sup>3</sup>						
Alarm Capability Trouble	Alarm Capability Trouble	Alarm Capability Trouble	Trouble	Alarm Capability Trouble	Alarm Capability Trouble	Trouble

Notes:

1. Trouble indicates a trouble signal will be generated at the control panel during the abnormal condition.

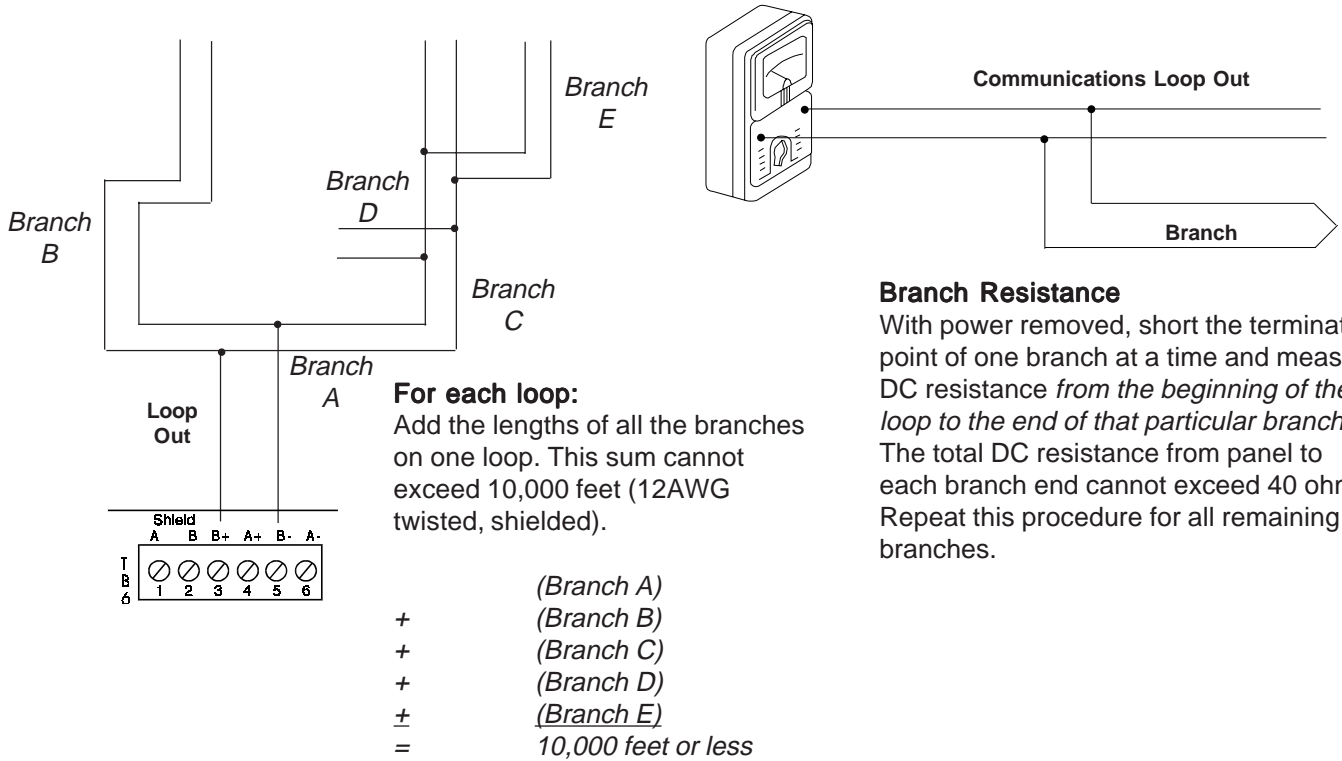
2. Alarm Capability indicates an alarm signal can be transmitted to the control panel during the abnormal condition.

3. Loop operation meeting Style 7 requirements isolates entire physical zone on the communications loop from faults that occur within other areas of the loop.



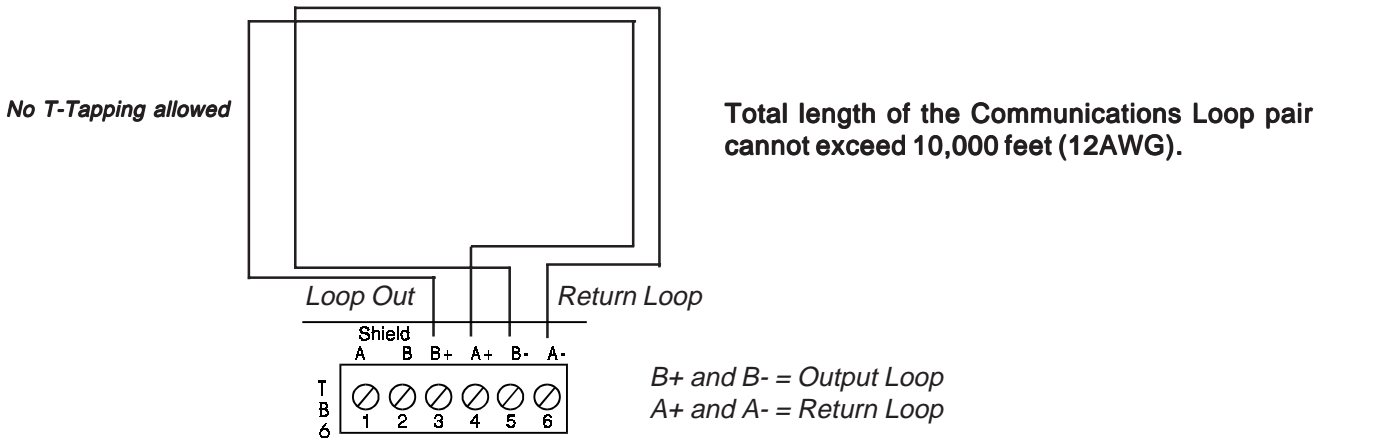
## Figure 2.5: Style 4 Wiring: T-tapping Restrictions and Branch Resistance

T-tapping of the SLC loop wiring is allowed for two wire (Style 4) configurations. The total resistance of any branch cannot exceed 40 ohms. Measure the resistance as illustrated below. The total wire length of all combined branches cannot exceed 10,000 feet.



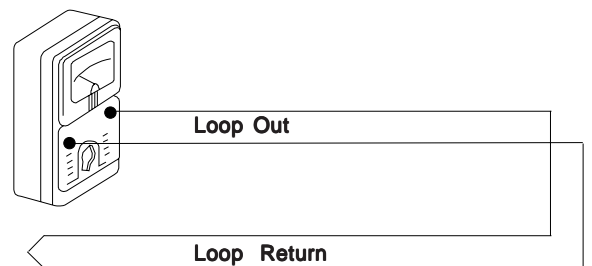
## Figure 2.6: Style 6 Wiring

T-tapping of the SLC loop wiring is not allowed for Style 6 configuration. The total resistance of the complete wire run cannot exceed 40 ohms and total length cannot exceed 10,000 feet. Measure the resistance as illustrated below.



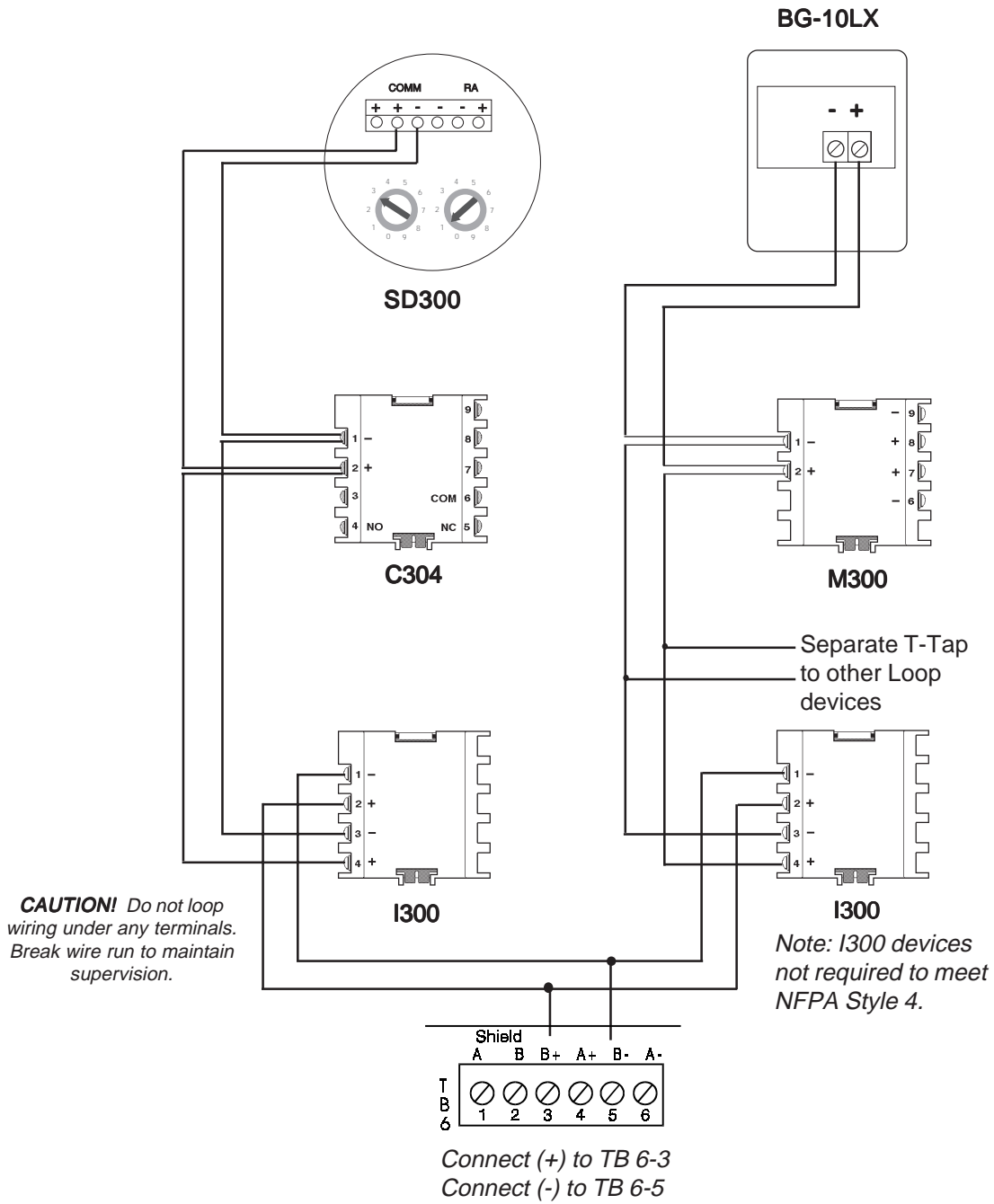
### DC Resistance of the Communications Loop pair cannot exceed 40 ohms.

With power removed, disconnect Loop Out and Return at the control panel, short the two leads of Communications Loop Return, and meter Loop Out.

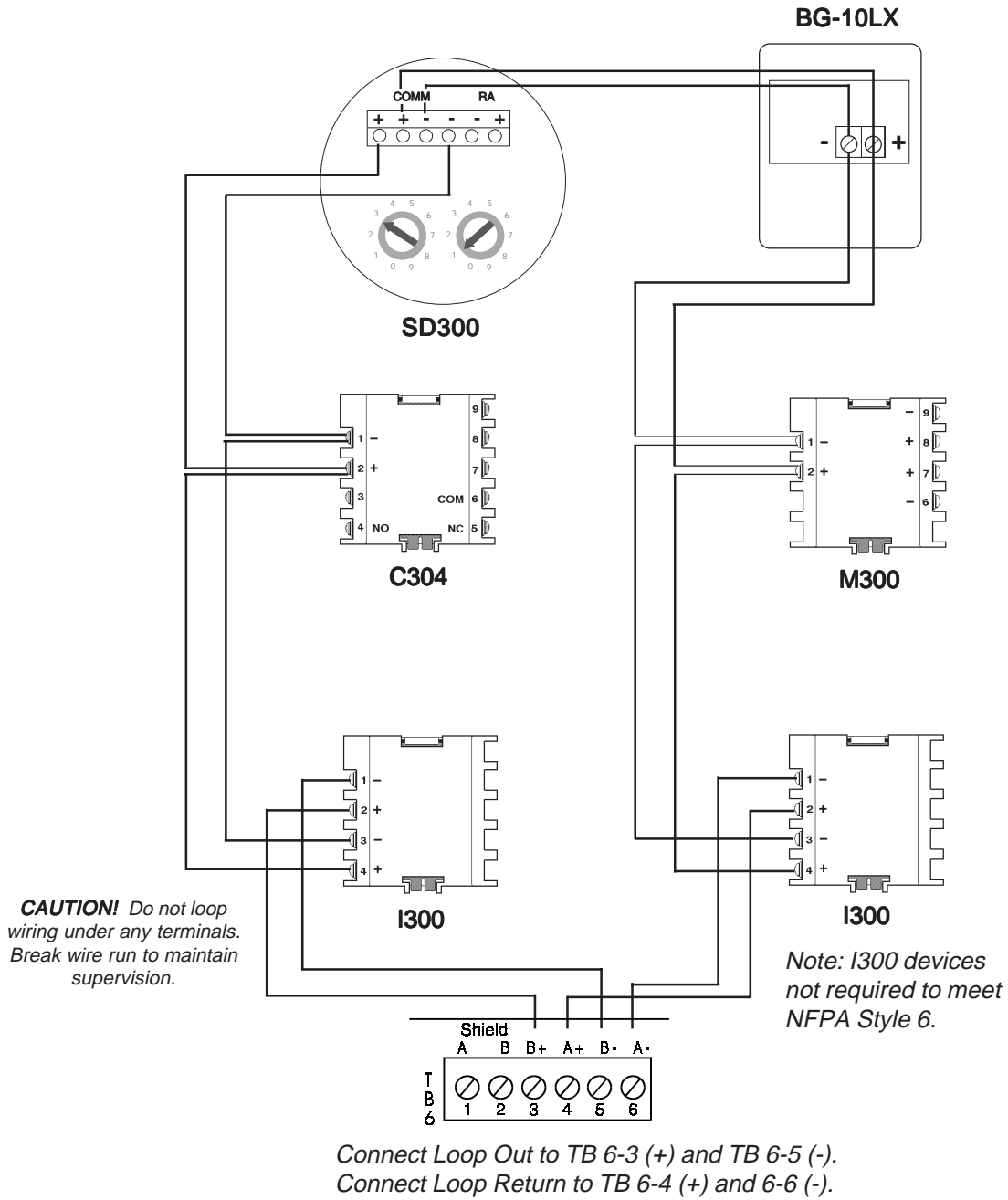


# Figure 2.7: Two-Wire Communications Loop (Supervised and Power-Limited)

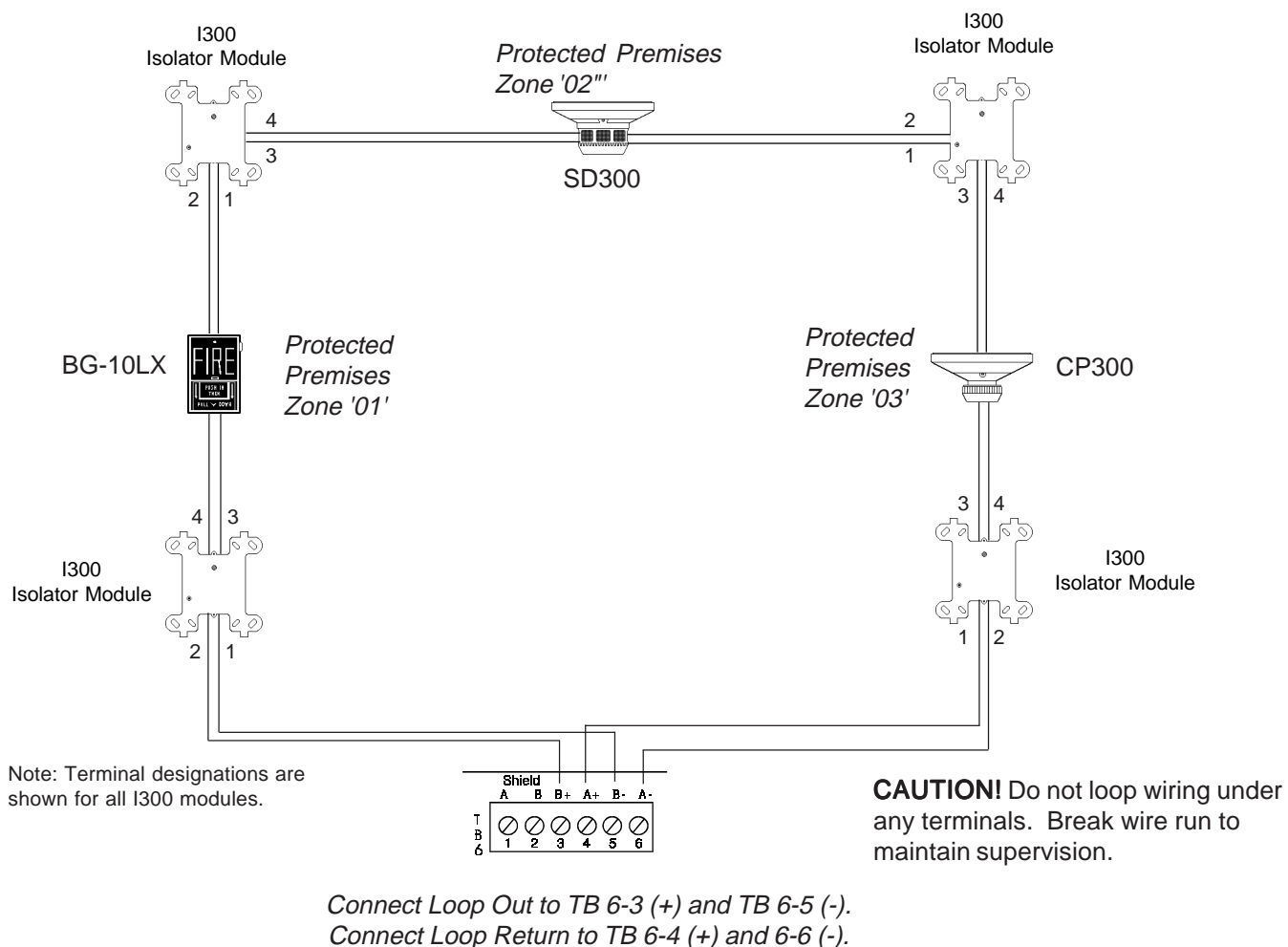
(meets NFPA 72 Style 4 requirements - may be T-tapped)



**Figure 2.8: Four-Wire Communications Loop (Supervised and Power-Limited)**  
 (meets NFPA 72 Style 6 requirements - cannot be T-tapped)



**Figure 2.9: Four-Wire Communications Loop**  
 (meets NFPA 72 Style 7 requirements - cannot be T-tapped)



**Operation**

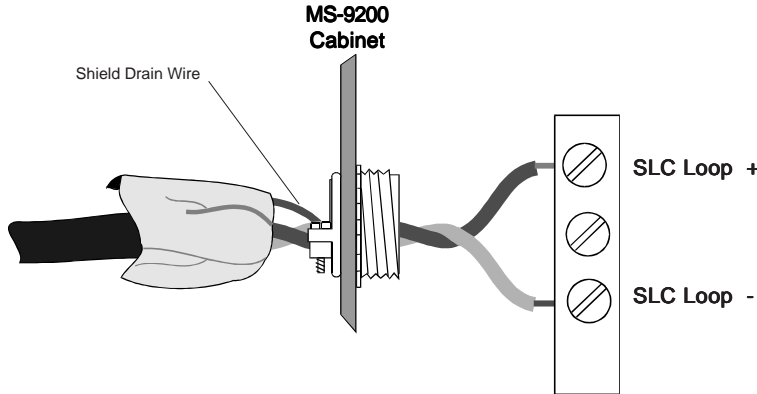
By 'flanking' each communications loop device with a pair of I300 Fault Isolator Modules, each device is protected from short circuit faults that may occur on other devices. For example, a fault on Zone 02 will not affect Zones 01 and 03. The isolator modules on either side of Zone 02 will open the Loop. Zone 01 will still operate from power on Loop Out and Zone 03 will operate from Loop Return. Since the MS-9200 will no longer be able to communicate with Zone 02, a trouble signal(s) will be generated for that device.

No T-Tapping or branching is allowed on this circuit. The ratings and characteristics are the same as for a four-wire circuit meeting NFPA Style 6 requirements.

### Shielded Wire Termination Requirements

Shielded wire is recommended for use on the SLC loop, EIA-485 and EIA-232 circuits (refer to Appendix F for additional wiring information). Proper termination of the shield is shown below for various applications such as no conduit, partial conduit and full conduit. Nonshielded wire (max. 1,000 feet) may be used on the SLC loop, however, full conduit is recommended for optimum EMI and RFI protection.

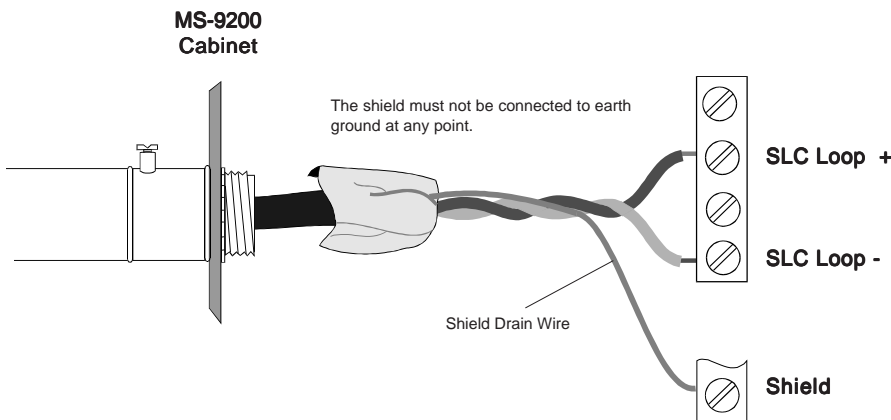
**Figure 2.10: Shield Termination in No Conduit**



#### All Styles of Wiring

Do not allow the shield drain wire to enter the system cabinet. Connect the drain wire to the outside of the cabinet via a BX-type connector.

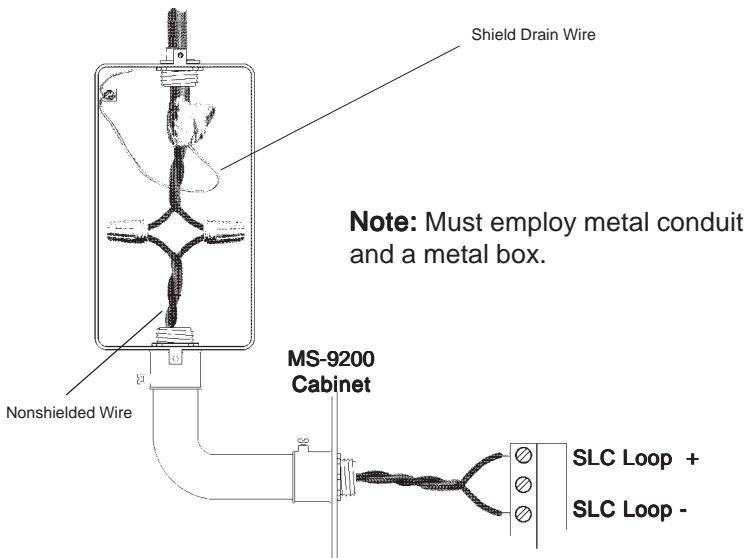
**Figure 2.11: Shield Termination in Full Conduit**



#### All Styles of Wiring

The shield drain wire must be connected to the shield terminal TB6, Terminal 1 or 2. Do not allow the shield drain wire or the shield foil to touch the system cabinet. For Style 6 or 7, connect only one end of the shield to TB6.

**Figure 2.12: Shield Termination in Partial Conduit**

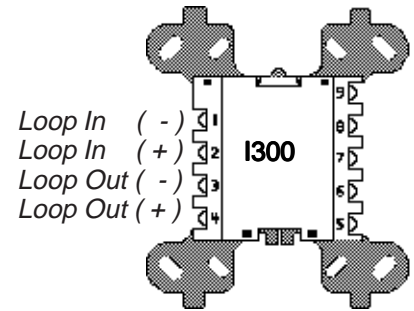


#### All Styles of Wiring

Do not allow the shield drain wire to enter the system cabinet or the conduit. Connect the drain wire to the termination point of the conduit run (such as a single-gang box as illustrated above). The conduit cannot be longer than 20 feet.

## 2.8 The Isolator Module

The Loop Isolator Module (I300) is used to protect critical elements of the communications loop from faults on other branches or sections of the loop. The I300 continuously monitors the circuit connected to terminals 1 (-), 3 (-), 2 (+) and 4 (+). Upon power-up, an integral relay is latched on. The I300 periodically pulses the coil of this relay. A short circuit on either side of the loop resets the relay. The I300 senses the short and disconnects the faulty branch by opening the positive side of the loop (terminal 2 or 4). This effectively isolates the shorted branch from the remainder of the loop. Once the fault is removed, the I300 automatically reapplies power to the communications loop branch. Figure 2.7 illustrates the use of an I300 on a two wire communications loop meeting NFPA Style 4 requirements; Figure 2.9 shows a four wire loop meeting NFPA Style 7 requirements.

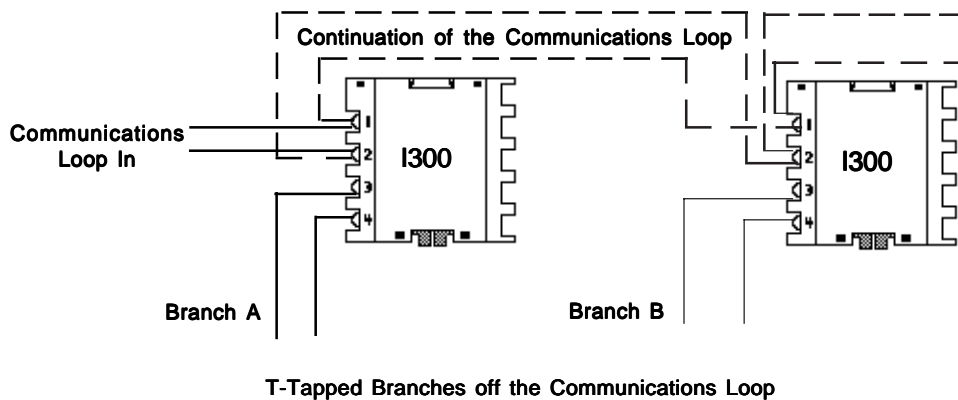


### Note:

During a fault condition, the MS-9200 will register a trouble condition for each device isolated on the loop branch.

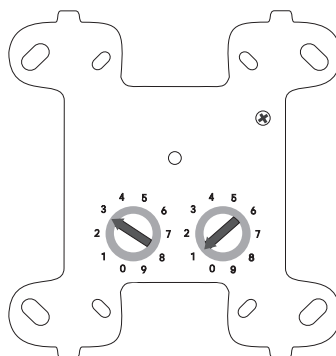
## Figure 2.13: Isolating Two-Wire Communications Loops

A short on any T-tapped branch off an I300 Isolator Module on the Communication Loop meeting NFPA Style 4 wiring requirements, will be isolated from all devices installed both upstream of the I300 (Communications Loop In) and on the continuation of the loop (shown as a dotted line). As an example, if a short were to occur on Branch A of the first I300 shown, the isolator module would disconnect Branch A and its devices from the rest of the Communication Loop, allowing all devices connected before and after that I300 to operate normally.



## 2.9 Module Addressing

Monitor and Control Modules have two rotary decimal switches which are used by the installer to set the module address. Addresses from 01 to 99 may be set by positioning the left rotary switch to the value of the '10's' digit and the right switch to the value of the '1's' digit. For example, address 31 would be set by pointing the left switch to 3 and the right switch to 1 as shown below.



## 2.10 The M300 Monitor Module

The M300 Monitor Module is an addressable module that monitors normally-open contacts and shorting-type alarm initiating devices. The supervised module circuits can be wired as NFPA Style B or Style D Initiating Device Circuits. There is no limit to the number of contact-type devices installed on a monitor module circuit. Refer to Figures 2.14 and 2.15 for wiring diagrams.

### COMMUNICATIONS LOOP CONNECTIONS

Connect the MS-9200 Communications SLC Loop to M300 terminals 1 (-) and 2 (+). The M300 occupies one module address on the Loop. Use the rotary switches on the M300 to set the module to the required loop address.

### NFPA STYLE B INITIATING DEVICE CIRCUIT

Connect the normally-open contacts of the alarm initiating devices to a single two-wire circuit (as shown in Figure 2.14). *NOTE: This circuit cannot be T-Tapped or branched in any fashion, and must be terminated across the last device by a listed ELR.* Connect the circuit to M300 terminals 6 (-) and 7 (+).

### NFPA STYLE D INITIATING DEVICE CIRCUIT

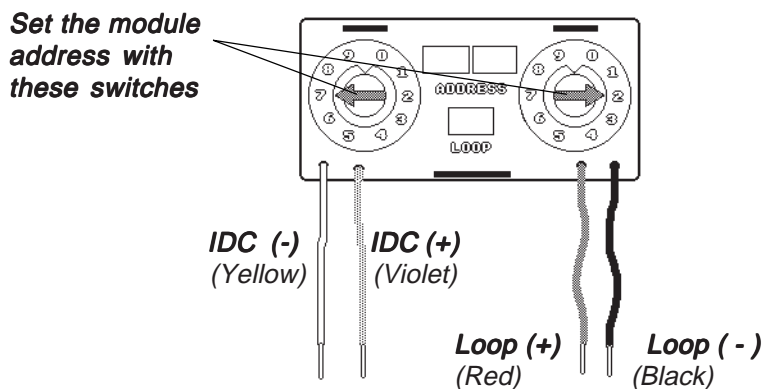
Connect the alarm initiating devices to a single four-wire circuit (as shown in Figure 2.15). *NOTE: This circuit cannot be T-Tapped or branched in any fashion.* Connect the four-wire circuit to M300 Terminals 6 (-) and 9 (-), then 7 (+) and 8 (+).

### TEST SWITCH

The M300 includes a magnetic test switch located near the center front of the module. Activation of this switch will cause an open circuit indication in the Style B/D loop.

## 2.11 The M301 Monitor Module

The M301 Monitor Module is an addressable module that is functionally and electrically identical to an M300 Monitor Module (Style B circuits only), but offered in a smaller package for mounting directly in the electrical box of the contact-type device being monitored.



### NFPA STYLE B INITIATING DEVICE CIRCUIT

Terminate with a 47K $\omega$ , 1/2 Watt ELR (N-ELR in Canada).

### NOTES ON THE M300 AND M301 MONITOR MODULES:

1. The Initiating Device Circuit is supervised and current-limited to 230 microamperes @ 24 VDC (nominal).
2. The Initiating Device Circuit wiring may be up to 2,500 feet or a maximum of 40 Ohms for the M300 and 20 Ohms for the M301.
3. The Initiating Device Circuit provides the following services (*DO NOT MIX*):
  - ✓ Fire Alarm Service.
  - ✓ Automatic/Manual Waterflow Alarm Service with normally-open contact devices.
  - ✓ Sprinkler Supervision with normally-open contact devices.
4. The maximum SLC loop resistance due to wiring is 40 Ohms.

## 2.12 The M302 Monitor Module

The M302 Monitor Module is an addressable module that interfaces and monitors UL compatible conventional 2-wire smoke detectors. (See Fire-Lite Compatibility Document P/N 15384.) The supervised circuit may be wired as NFPA Style B or D.

### COMMUNICATIONS SLC LOOP CONNECTIONS

Connect the MS-9200 Communications SLC loop to M302 terminals 1(-) and 2(+). The M302 occupies one module address on the loop. Use rotary switches on the M302 to set the module to the required loop address.

### NFPA STYLE B INITIATING DEVICE CIRCUIT

Connect 2-wire smoke detectors to M302 terminals 6 (B-) and 7 (B+) (as shown in Figure 2.16). IDC installation wiring must not exceed 25 ohms, 12-18 AWG wire. Use a 3.9K ELR across the last initiating device. (See Figure 2.16).

### NFPA STYLE D INITIATING DEVICE CIRCUIT

Connect 2-wire smoke detectors to M302 terminals 6 (B-) and 9 (D-), 7 (B+) and 8 (D+) (as shown in Figure 2.17). IDC installation wiring must not exceed 25 ohms, 12-18 AWG wire. (See Figure 2.17).

### POWER CONNECTIONS

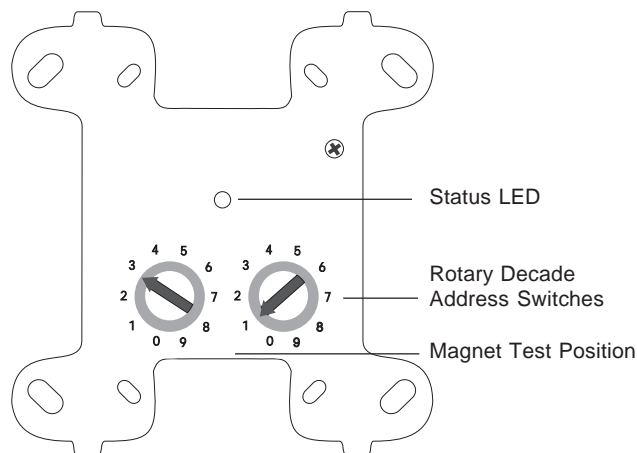
Power must be switched 24VDC isolated regulated and battery backed. Connect to M302 terminals 3 (-) and 4 (+) (as shown in Figures 2.16 and 2.17).

### NOTES ON M302 MONITOR MODULE

1. IDC and power connections are supervised by the M302 and reported to the MS-9200
2. Maximum current in alarm is 90 mA power limited
3. See Appendix F for device specifications
4. See Appendix A for power supply calculations

### TEST SWITCH

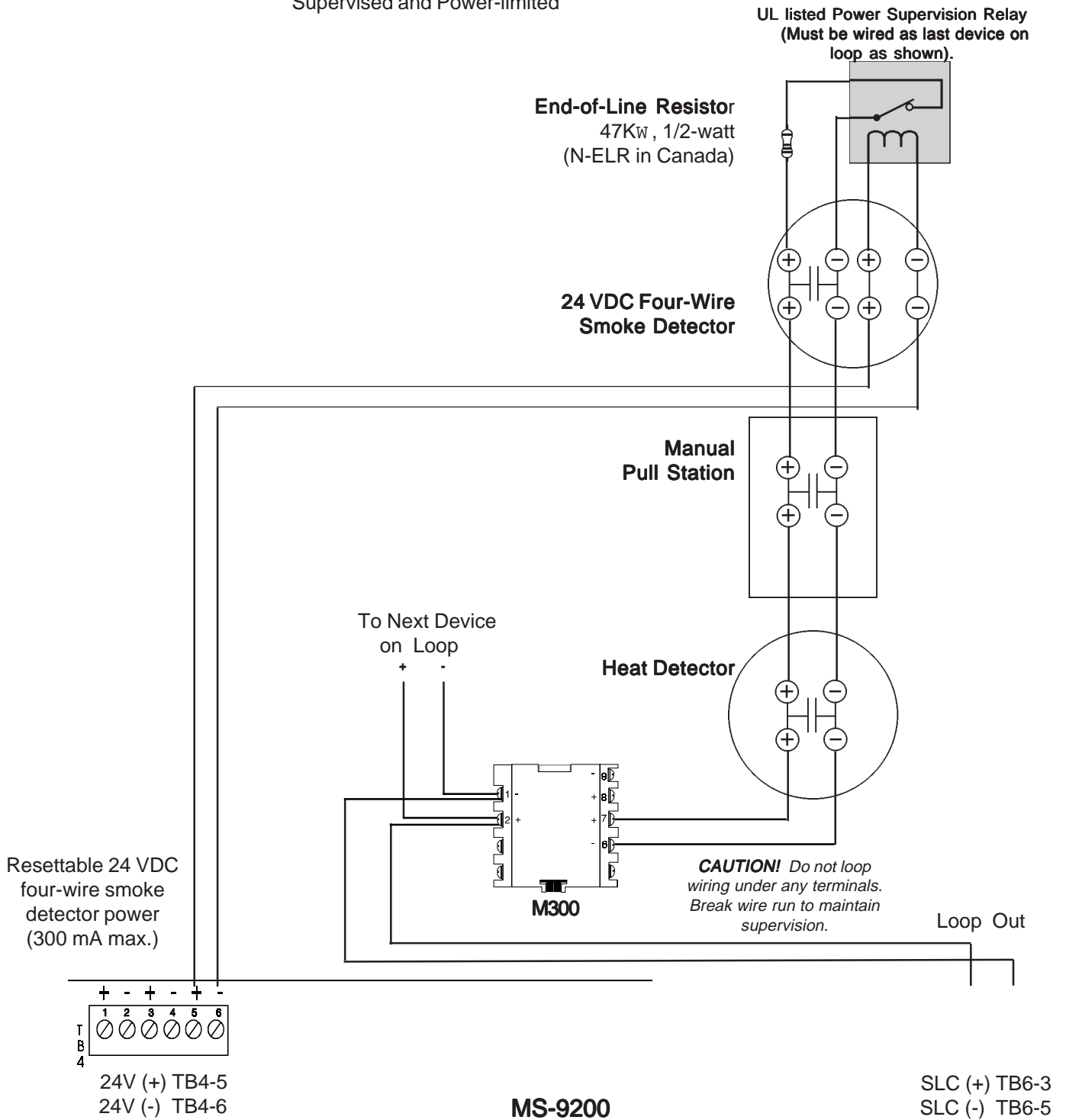
The M302 includes a magnetic test switch sensor located near the center front of the module. Activation of this switch by test magnet P/N M02-04-00 will cause an open circuit indication in the Style B/D loop.



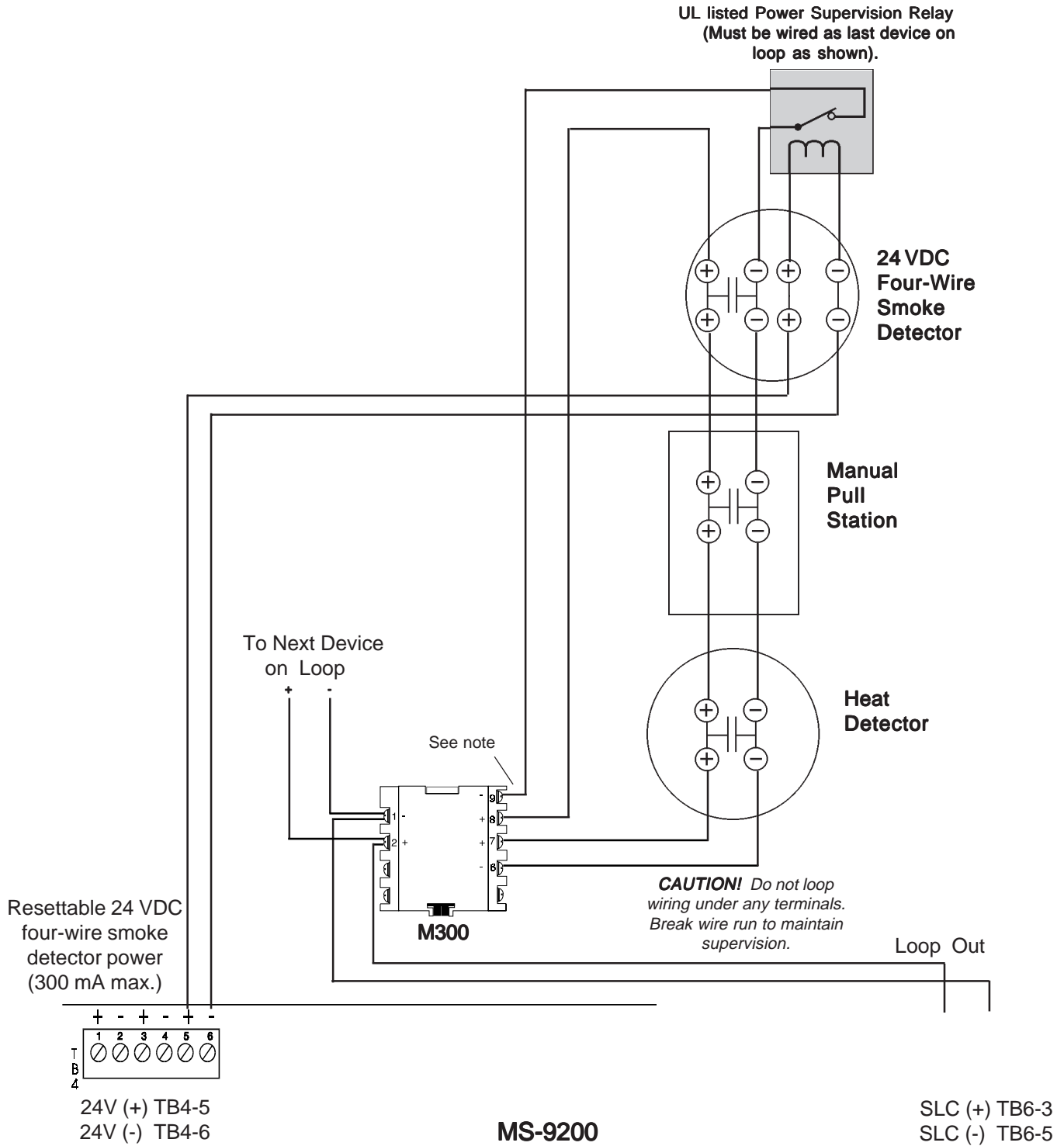


**Figure 2.14: NFPA Style B Initiating Device Circuit (Utilizing M300 Monitor Module)**

Supervised and Power-limited

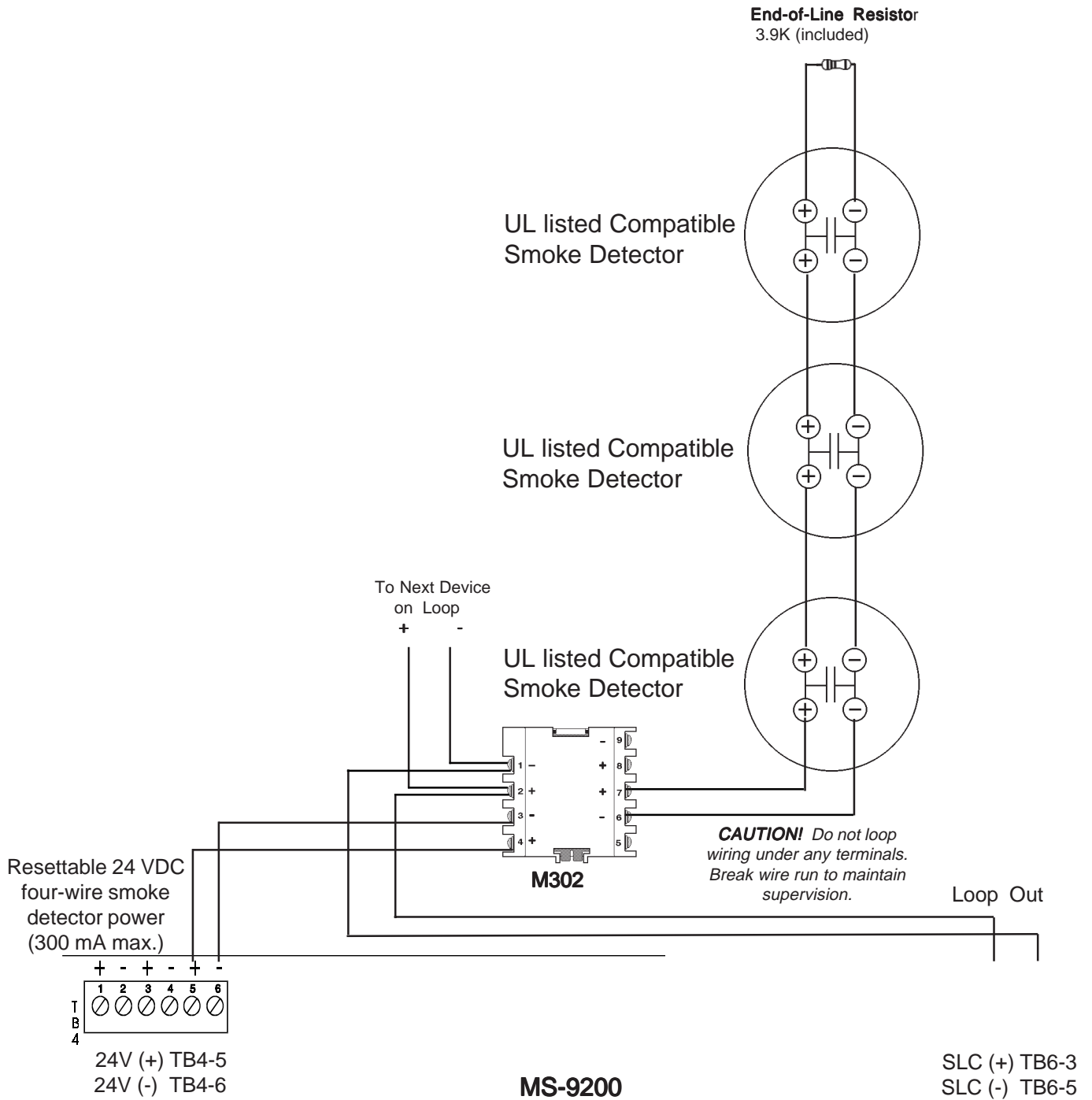


**Figure 2.15: NFPA Style D Initiating Device Circuit (Utilizing M300 Monitor Module)**  
 Supervised and Power-limited

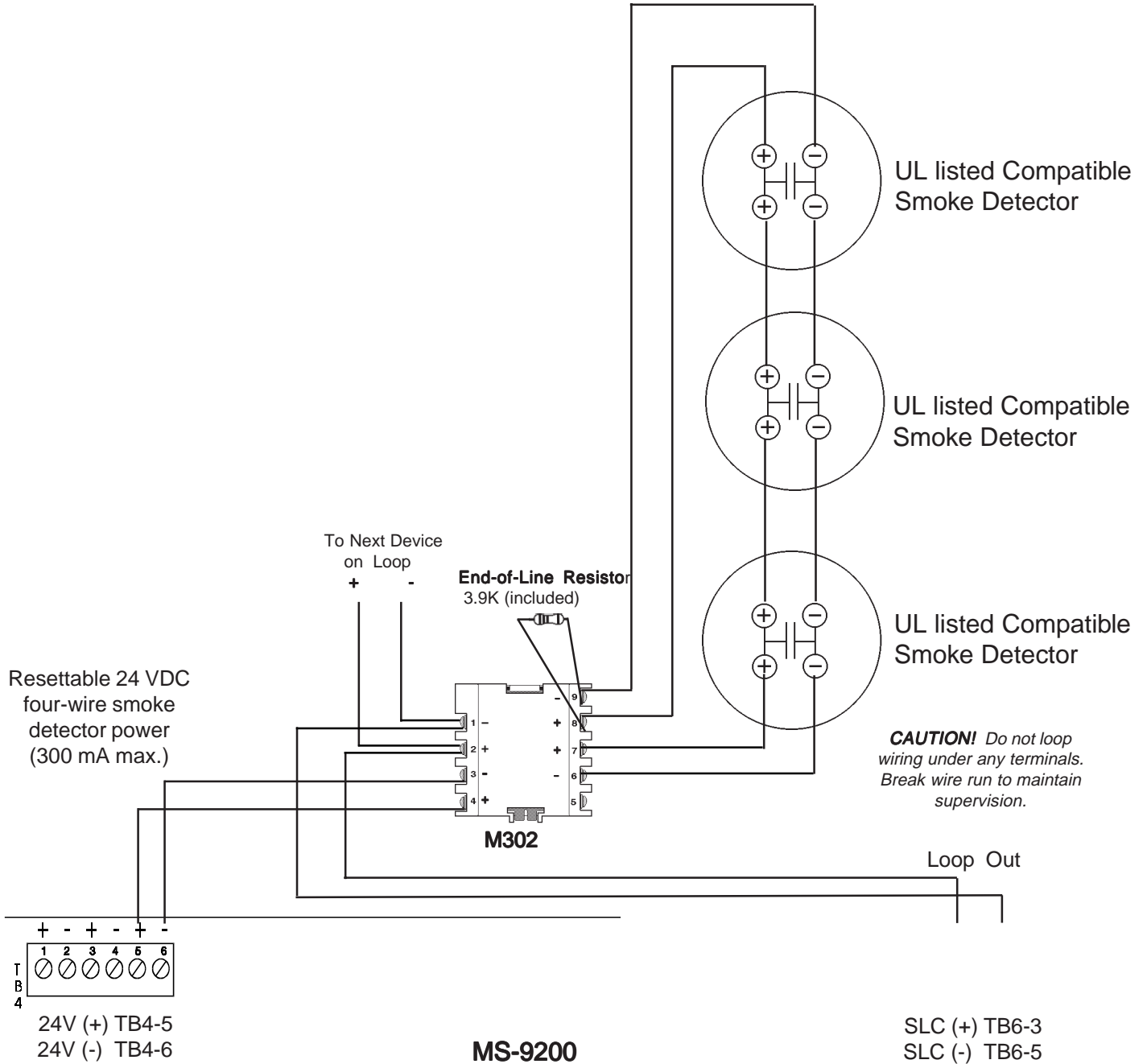


Note: ELR is not required when wiring Style D (Class A).

**Figure 2.16: NFPA Style B Initiating Device Circuit (Utilizing M302 Monitor Module)**  
 Supervised and Power-limited



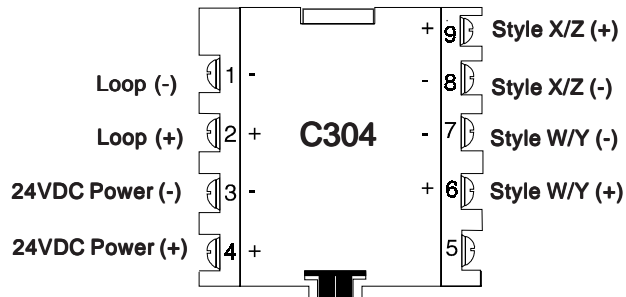
**Figure 2.17: NFPA Style D Initiating Device Circuit (Utilizing M302 Monitor Module)**  
 Supervised and Power-limited



## 2.13 The Control Module

The C304 Control Module is an addressable module that supervises and switches power to a Notification Appliance Circuit. The C304 can be wired as NFPA Styles W, X Y or Z Notification Appliance or Speaker Circuits. Alternately, the C304 module can be employed as a Form-C control relay.

**Figure 2.18: The C304 Control Module (Alarm polarity shown)**



### COMMUNICATIONS LOOP CONNECTIONS

Connect the MS-9200 Communications SLC Loop to C304 terminals 1 (-) and 2 (+). The C304 occupies one module address on the Loop. Set the rotary switches on the C304 to the particular Loop address required.

### NFPA STYLE W OR Y NOTIFICATION APPLIANCE OR SPEAKER CIRCUIT

Connect polarized alarm Notification Appliances or speakers to a single two-wire circuit. *NOTE: This circuit cannot be T-Tapped or branched in any fashion, and must be terminated across the last device by a 47K $\Omega$ , 1/2-watt ELR (Part # A2143-00).* Connect the circuit to C304 terminals 6 (+) and 7 (-). See Figure 2.19.

### NFPA STYLE X OR Z NOTIFICATION APPLIANCE OR SPEAKER CIRCUIT

Connect polarized alarm Notification Appliances or speakers to a single four-wire circuit. Connect the circuit to C304 terminals 6 (+), 9 (+), 7 (-) and 8 (-).

### NOTIFICATION APPLIANCE POWER

Connect Notification Appliance power from MS-9200 TB4 terminal 1 to C304 terminal 4 (+24 VDC) and MS-9200 TB4 terminal 2 to C304 terminal 3 (-24VDC). This power must be supervised by a UL listed Power Supervision Relay, wired as shown in Figure 2.20.

### CODED OPERATION

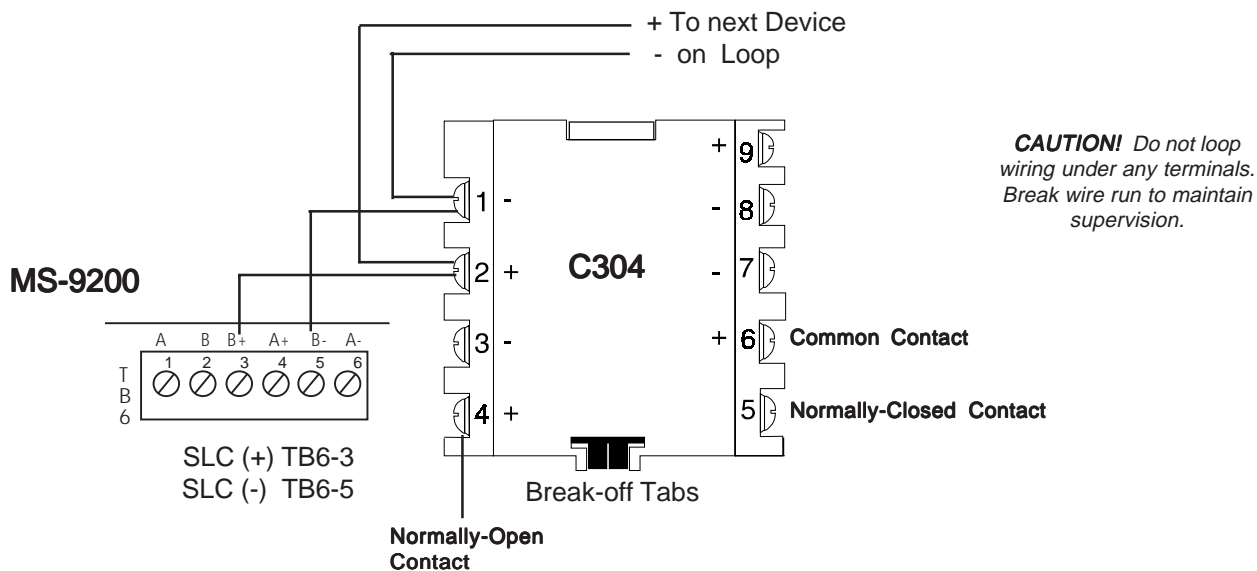
Connect Notification Appliance power from either TB1 (NAC 1 Output) terminals 1 and 4 or TB2 (NAC 2 Output) terminals 1 and 4 to C304 Control Module terminals 3 and 4. Be certain to place an ELR across the last device on the module (use only one ELR) for Style B operation. Set NAC 1 or NAC 2, which is now used to drive the C304, for appropriate coded function. Refer to Section 3.2.03 Point Edit for additional information.

Note: When wiring Style Z, do not install an ELR since one is built into the C304 Control Module.

### TEST SWITCH

The C304 Control Module includes a magnetic test switch sensor located near the center front of the module. Activation of this switch by test magnet P/N M02-04-00 will cause a short circuit indication for the Style W/X/Y/Z circuit connected to the module.

**Figure 2.19: The C304 Control Module (Utilized as a Form-C Relay)**



**BREAK TABS**

To configure a C304 as a Form-C relay, the two break-off tabs shown must be broken off of the module. Use a pair of needle-nose pliers to break off each tab.

**Caution:** Failure to break tabs when configuring for Form-C Relay operation can cause damage to the C304 module.

**COMMUNICATIONS LOOP CONNECTIONS**

Connect the MS-9200 Communications SLC Loop to C304 Terminals 1(-) and 2(+). The C304 occupies one module address on the Loop. Set the rotary switches on the module to the particular Loop address required.

**CONTACT CONNECTIONS**

Wire the common and the normally-open or normally-closed contacts to the module as needed.

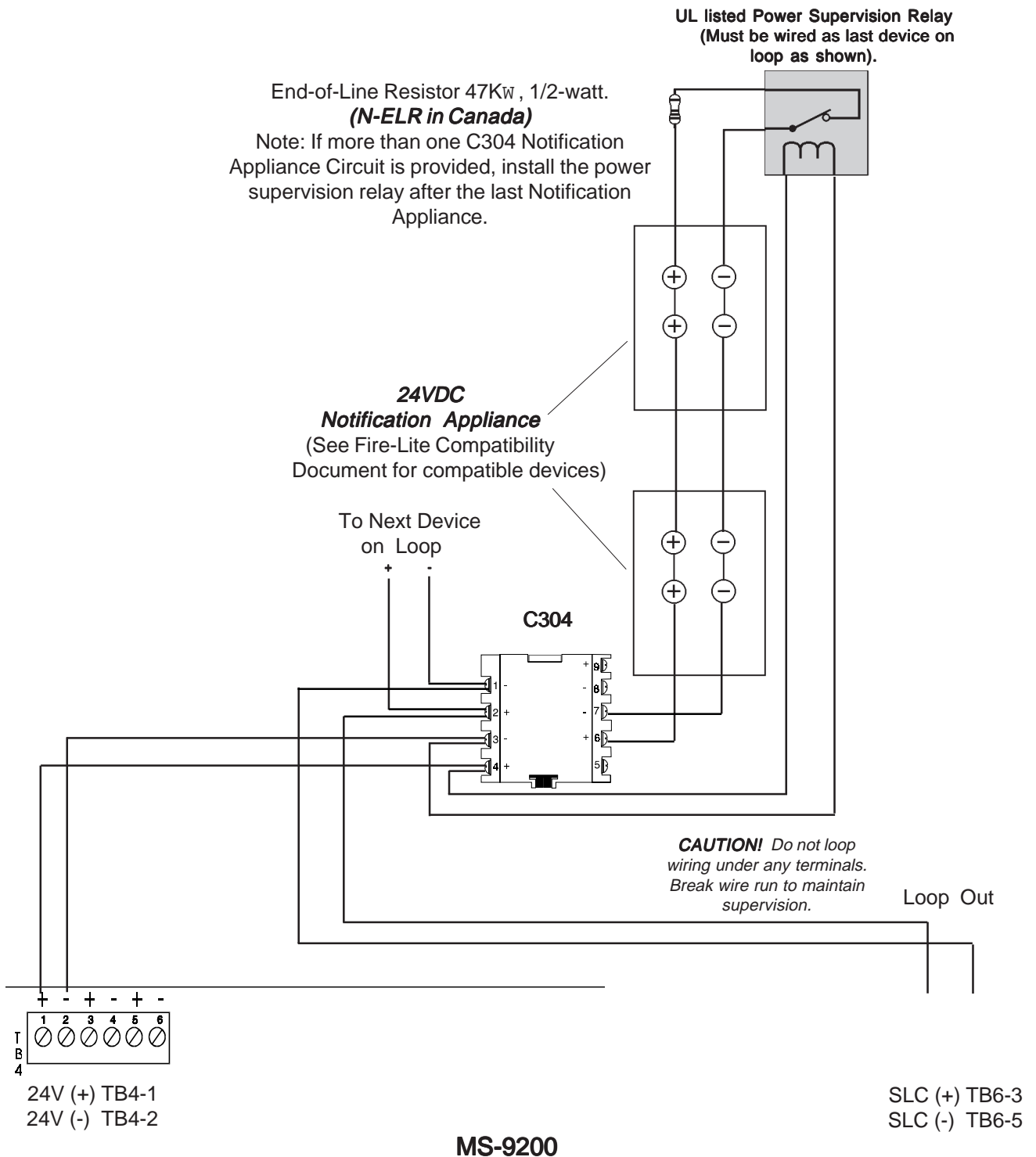
**CONTACT RATINGS**

- Resistive: 2 Amps @ 30 VDC\*
- Inductive: 1 Amp @ 30 VDC (0.6 PF)
- Pilot Duty: 0.6 Amps @30 VDC (0.35 PF)
- 0.3 Amps @ 110 VDC (0.35 PF)
- 0.3 Amps @ 120 VAC (0.35 PF)

\*Certain electromechanical devices exhibit inductive loading characteristics. For these types of devices, derate the outputs to 1 Amp. Refer to the Device Compatibility document for load characteristics by device.

# Figure 2.20: NFPA Style Y Notification Appliance Circuit (Utilizing C304 Module)

All circuits are supervised and power-limited





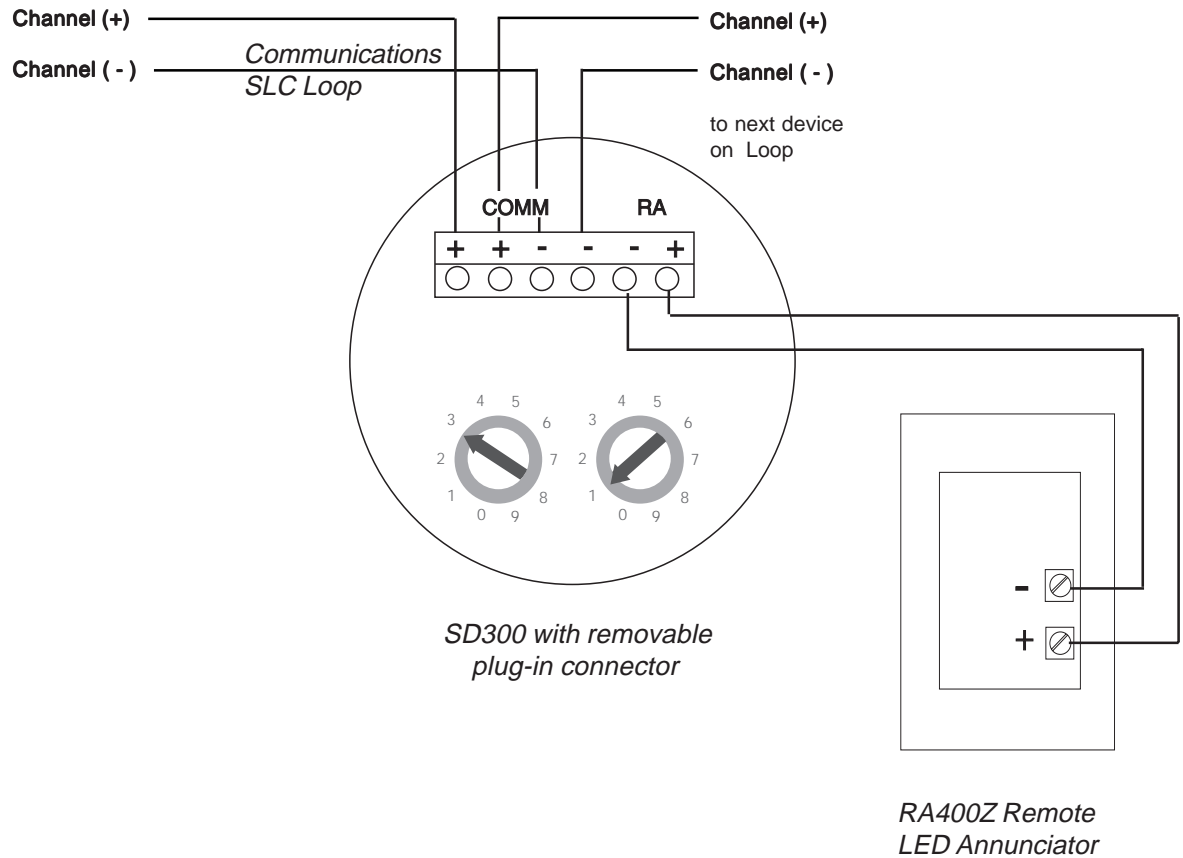


## 2.15 Wiring Detectors

### INSTALLATION

- Connect the MS-9200 Communications SLC Loop to Terminal (-) and Terminal (+) of the removable terminal block.
- If an RA400Z Remote LED Annunciator is being employed, connect the RA400Z positive terminal to the RA+ terminal on the removable terminal block and the negative terminal to the RA(-) terminal on the removable block.
- Before installing the appropriate addressable detector head, set the detector's address on the head with a small slotted screwdriver. Mark this address on the head.
- Place the removable terminal block into the connector in the detector head. Be certain to align properly and snap-in securely.

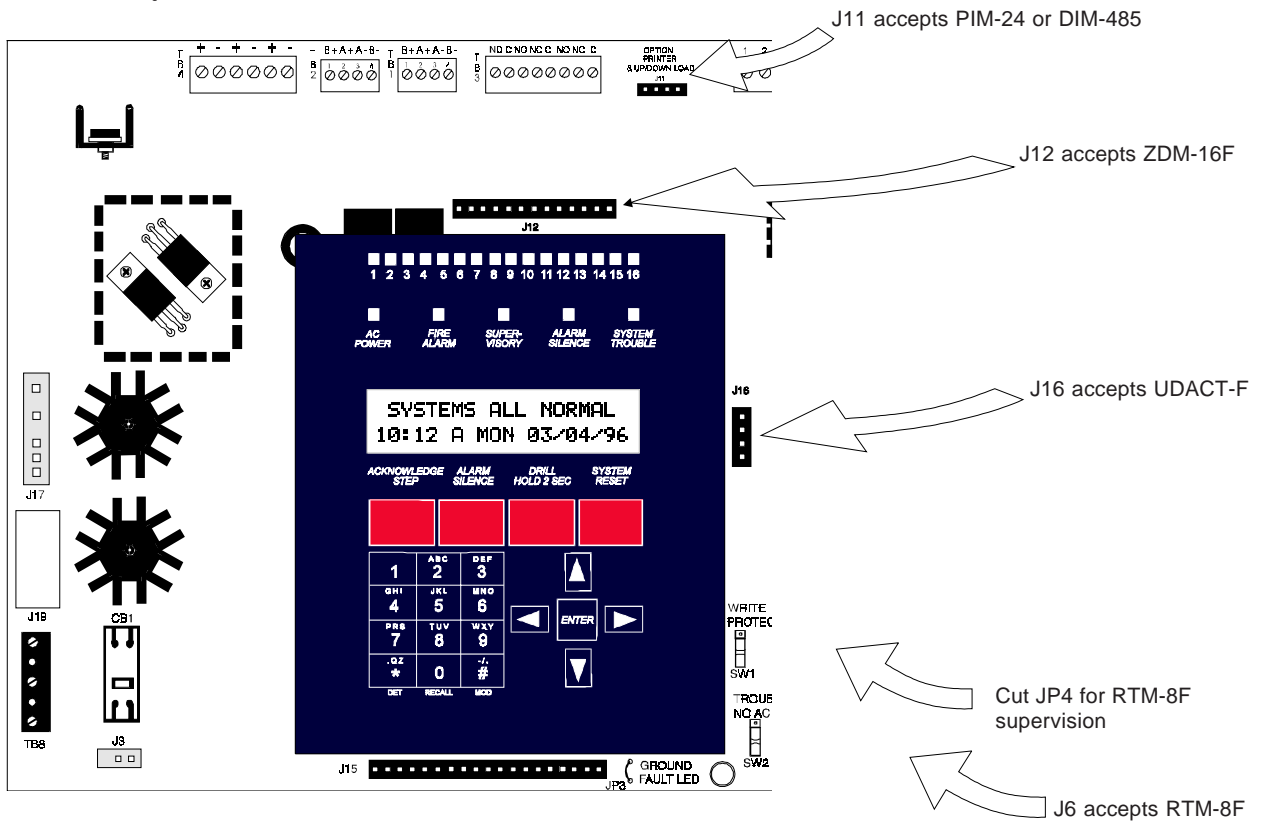
Figure 2.22: Wiring the Detector With Removable Plug-in Connector



## 2.16 Optional Modules

The MS-9200 supports option modules, using connectors J6, J11, J12 and J16 on the main board. There are five optional modules available for the MS-9200; the RTM-8F Relay/transmitter Module, PIM-24 Printer/PC Interface Module, the UDACT-F Universal Digital Alarm Communicator Transmitter, the DIM-485 LCD-40 Display Interface Module and the ZDM-16F 16 zone LED Module. Jumper JP4 must be cut before installation of the RTM-8F optional module to enable module placement supervision. Note that devices connected to the standard EIA-485 connector, the optional EIA-232 connector, the optional EIA-485 connector (via the PIM-24 or DIM-485) or SLC Loop may be protected from voltage transients by using one of the compatible surge suppressors listed in Table G-1 of the appendix.

**Figure 2.23: Optional Module Location**

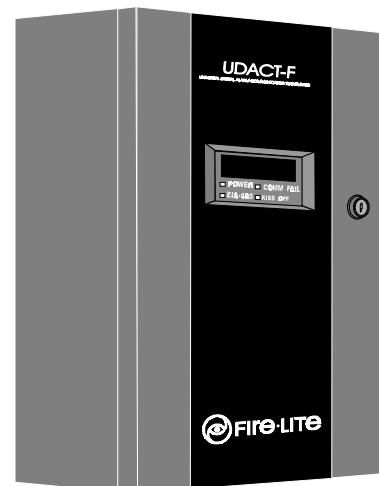


**MS-9200 Main Circuit Board**

## Communicators

### UDACT-F Universal Digital Alarm Communicator Transmitter

Transmits system status to UL Listed Central Station Receivers via the public switched telephone network. It is capable of reporting up to 56 software zones or up to 198 addressable points. The UDACT-F may be mounted directly to the MS-9200 main circuit board, or remotely in a UBS-1F (as shown) or ABS-8RF enclosure. The MS-9200 requires software P/N 73580 or higher to support the UDACT-F. For additional information, refer to the UDACT-F Manual P/N 50050.



**UBS-1F Enclosure**

## UDACT-F Mounting Options

The UDACT-F may be mounted directly to the MS-9200 main circuit board or remotely in an ABS-8RF or UBS-1F enclosure up to 6,000 feet away from the control panel. All power must be removed from the Control Panel before making any connections to prevent circuit damage. The EIA-485 serial interface is connected between the Control Panel and UDACT-F using twisted, shielded pair wire. Power should be wired from the Control Panel's 24VDC (nominal) filtered, nonresettable output to TB1 on the UDACT-F (except when mounted in the MS-9200).

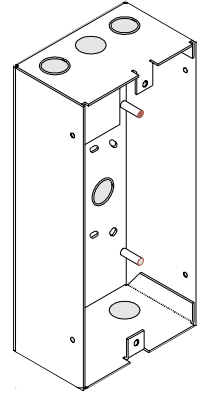


Figure 2-24: ABS-8RF Enclosure

## Mounting Inside MS-9200 Enclosure

The MS-9200 must have firmware with a Part Number of 73580 or higher installed to allow use of the UDACT-F. Remove all power from the MS-9200 by disconnecting AC and batteries. Install the supplied standoffs (three nylon and one aluminum standoff) in the appropriate holes located on the right side of the MS-9200 main circuit board as illustrated in Figure 2.25. Position J10, located on the back of the UDACT-F, over connector J16 which is located center right on the main MS-9200 circuit board, and carefully connect. Secure the UDACT-F to the aluminum standoff with the screw provided. *Caution: Damage can occur if female connector J10 is not properly aligned with male connector J16.*

The EIA-485 circuit and 24VDC power are provided directly from connector J16 of the MS-9200. Note: A 120 ohm EOL resistor is not required on the UDACT-F EIA-485 terminals when it is installed inside the MS-9200 cabinet. The EOL resistor is required at the last device on the EIA-485 line external to the MS-9200 panel.

## Programming

Refer to System Edit in the Programming/Read Status Section of this manual for information on programming the MS-9200 to function with the UDACT-F.

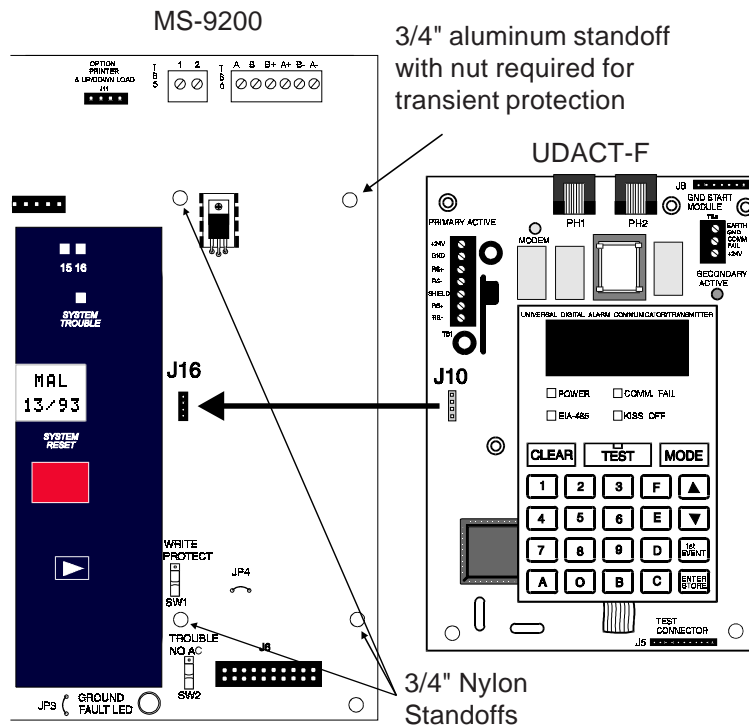
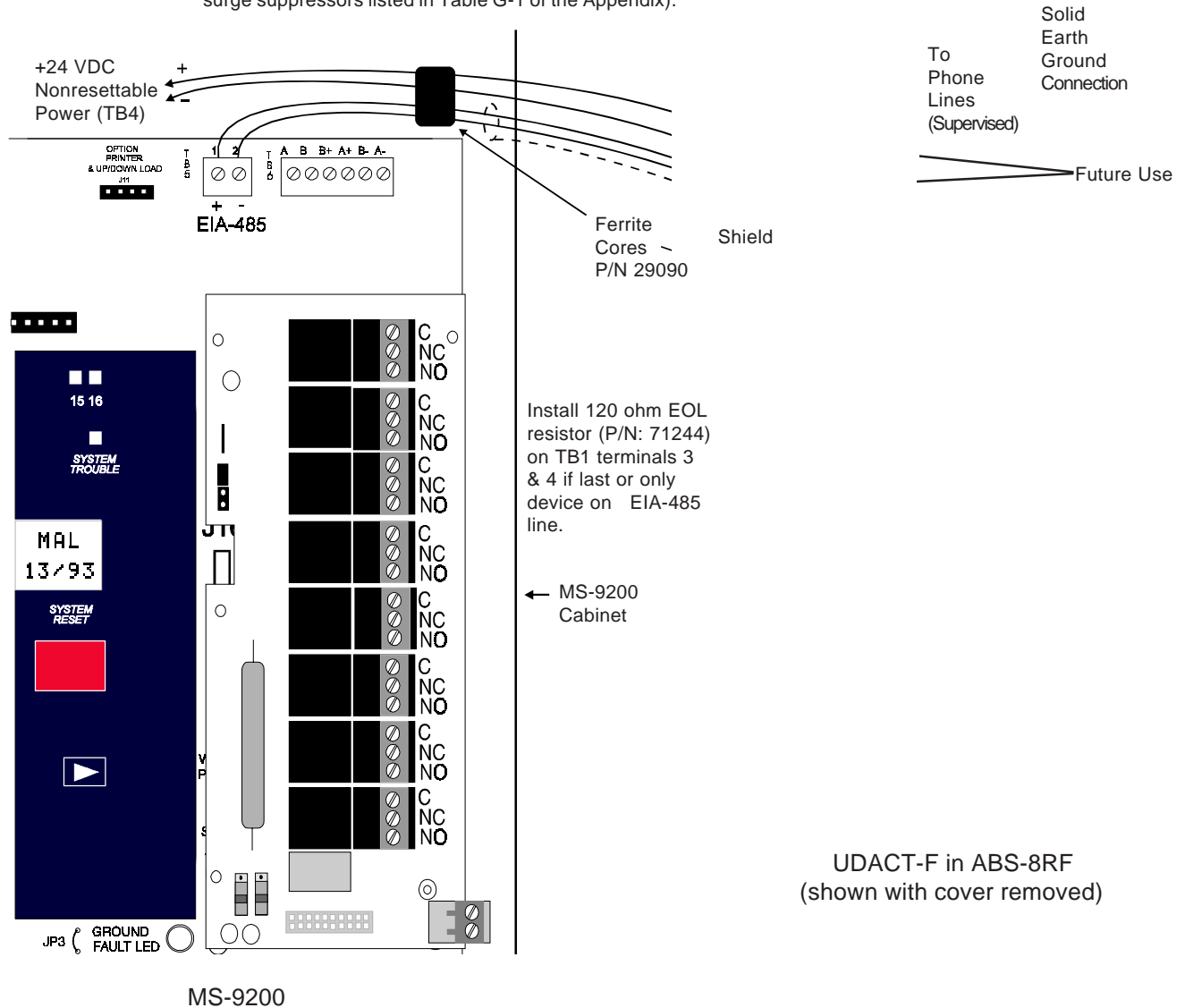


Figure 2.25: UDACT-F Mounting to MS-9200

Supervised and Power Limited EIA-485 and power connections.  
 (Surge protection can be provided by using one of the compatible surge suppressors listed in Table G-1 of the Appendix).



Notes:

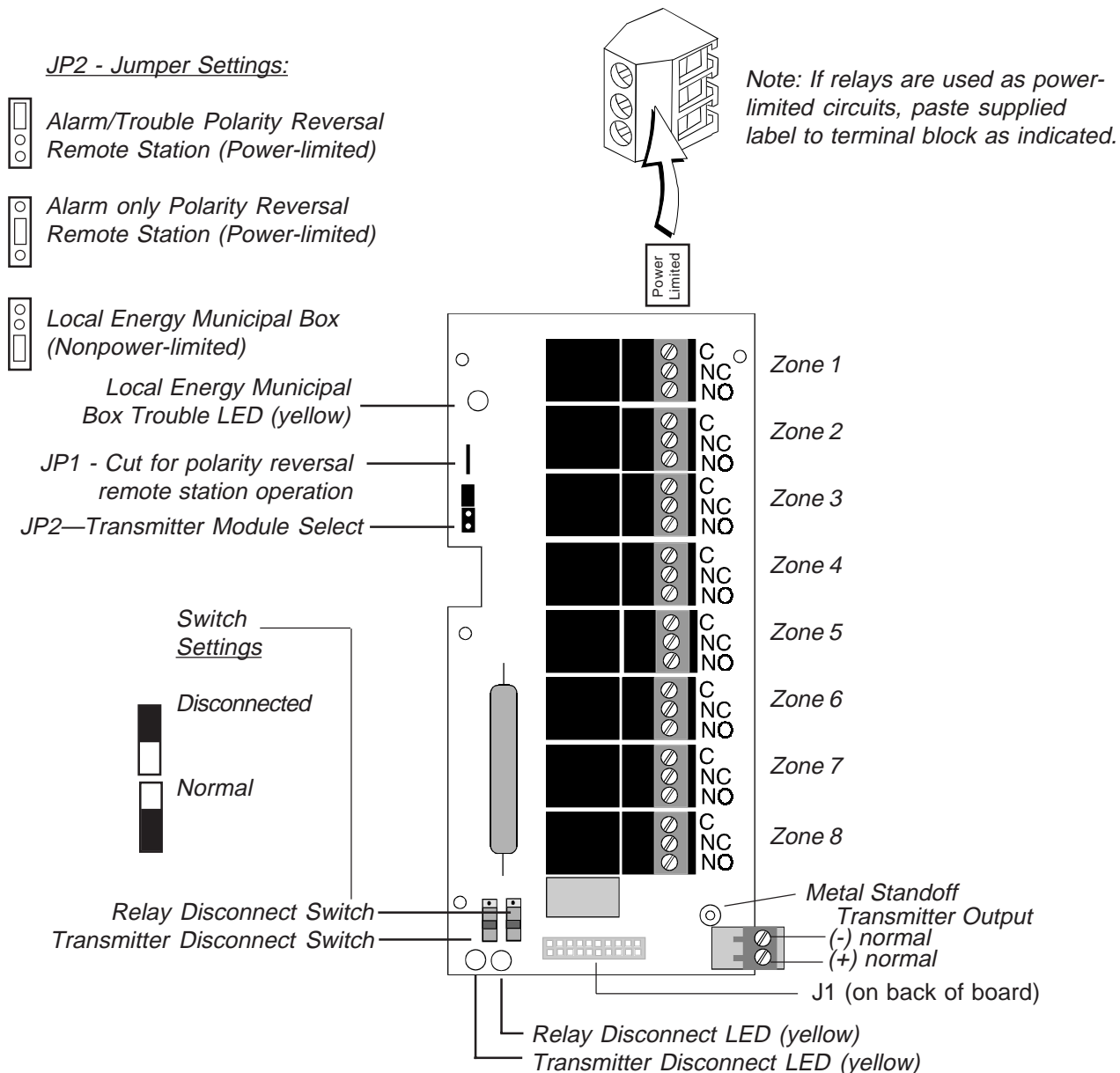
- 1) This arrangement allows use of the UDACT-F simultaneously with the RTM-8F module.
- 2) Ferrite cores are recommended for all applications.
- 3) Recommended wire is 12 AWG to 18 AWG twisted/shielded pair.
- 4) If shielded wire is used, connect only one end of shield:
  - a) shield may be connected to cabinet (earth ground) at fire alarm panel, or
  - b) shield may be connected to TB1 Terminal 5 (Shield) at UDACT-F. *NOTE: The shield end that is not connected should be insulated to prevent accidental grounding. Do not connect both ends of shield under any circumstance since a ground fault may result.*
- 5) Conduit is recommended for external wire runs. Consult local building codes.
- 6) Connect Ground Strap (supplied with ABS-8RF enclosure) from Earth Ground terminal on UDACT-F to a solid building earth ground. Conduit alone will not provide a reliable earth ground.
- 7) UDACT-F may be located up to 6,000 feet away from the host control panel.
- 8) Refer to Specifications Section for power requirements.
- 9) UDACT-F TB1 Terminals 6 and 7 are for future use.

**Figure 2.26: External UDACT-F Mounting in ABS-8RF**





**Figure 2.29: RTM-8F Relay Transmitter Module**



**Notes:**

- 1) Zone Relay Contact Ratings  
 Max. Switched Power: 170W or 1800VA    Max. Switched Current: 6 amps    Max. Switched Voltage: 30VDC or 300VAC  
 UL Rating: 6A @ 28VDC or 120/300VAC    1/8HP @ 120/240VAC (100,000 CYC)    1.5/0.8 A at 120/240 VAC, Pilot Duty 30,000 CYC  
 Contact Material: Silver Nickel, Gold Plated
- 2) Polarity Reversal Output: 24VDC (nominal), 18.5mA max. rated current Internal Resistance: 1200 ohms (nominal)  
 Intended for connection to the polarity reversal circuit of a remote station receiving circuit (such as the Fire-Lite RS-82) having compatible ratings. The RTM-8F is not suitable for separate transmission of both alarm and trouble signals simultaneously to a remote station. Output is power-limited and wiring can leave the building.
- 3) Municipal box output: Supervised for open circuit. Output is nonpower-limited and wiring can leave the building. Yellow Trouble LED when on indicates open circuit condition. Check wiring and make certain Municipal Box is reset according to local codes. Max. current (short circuit): 0.6 amp    Max. Voltage (open circuit): 30.0V  
 Max. Wire Resistance: 3 ohms
- 4) To prevent the yellow Trouble LED from turning on when the Transmitter Output is not used (no connections), move jumper JP2 to the Local Energy Municipal Box position (bottom two pins) and install a dummy load across the Transmitter Output terminals as shown below. The dummy load is a 1N4004 diode. The cathode must be connected to the terminal labeled '(-) normal' in Figure 2.29 above, and the anode must be connected to the terminal labeled '(+) normal'. Polarity must be observed or the Trouble LED will remain on. *Caution: Diode must be removed when using the Transmitter Output in order to properly supervise the connections.*



## 2.17 Printer/PC Interface Module

A remote serial printer may be permanently connected to provide a hard-copy printout of program entries, history file and walktest data. The Printer/PC Interface Module Part Number PIM-24 provides an EIA-232 conversion to adapt to most 40 and 80 column printers and most IBM PC/XT/AT or compatible computers including laptops and personal computers. (This option is not available simultaneously with use of the DIM-485/LCD-40).

**CAUTION:** *DO NOT connect a printer or PC to the MS-9200 Fire Alarm Control Panel if a ground fault exists on the panel. Circuit damage may result.*

### PROGRAMMING

Refer to System Edit in the Programming/Read Status Section of this manual for printer programming instructions.

### INSTALLATION

Remote printers and PCs require a separate 240 VAC, 50Hz primary power. Also required is the PIM-24 which includes the Printer/PC Interface Module, interface cable prewired to a DB9F connector as shown in Figure 2.30 and a DB25 adapter. Connect the Printer/PC Interface board to J11 on the MS-9200 main circuit board and the attached cable to the serial EIA-232 port on the printer or PC. Use the DB25 adapter if a nine pin connector is not available on your printer or PC. Note that a ground fault may occur on the MS-9200 panel, dependent upon the printer used, when this connection is made. For this reason, it is important that there be no preexisting ground fault on the panel. Consult the factory for recommended printers.

### PRINTER CONFIGURATION

The PIM-24 is required. Also refer to the documentation supplied with your printer. Set the printer's options as listed in the table which follows.

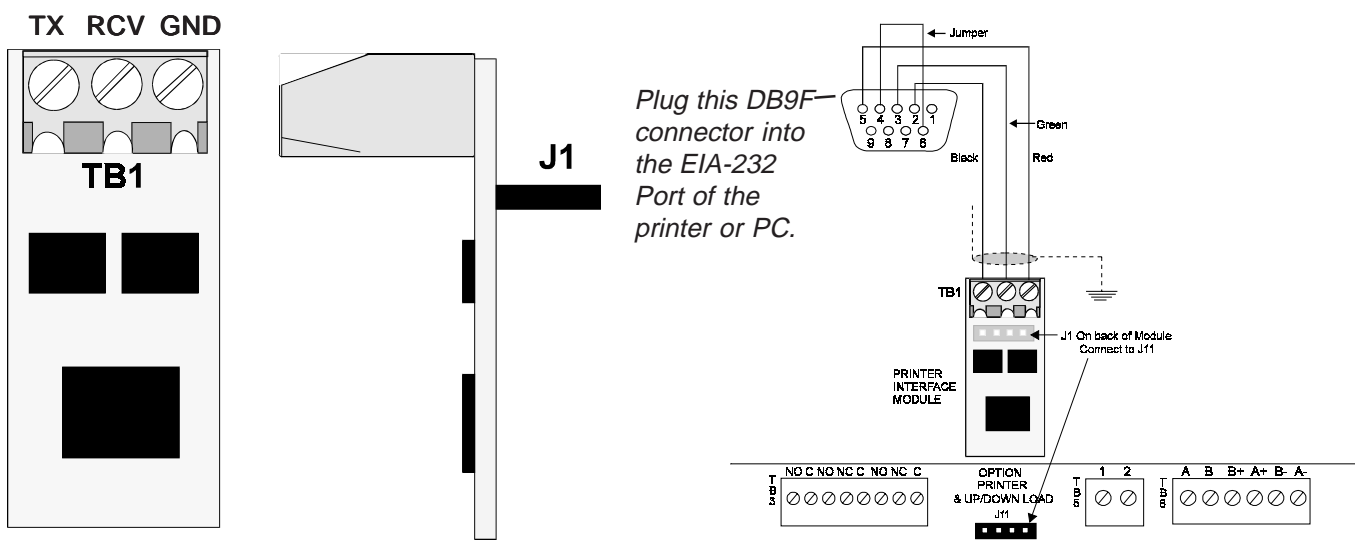
Typical Printer Settings	
<b>COMMUNIC. SETUP:</b>	
BUFFER:	LARGE
DATA BITS:	7
PARITY:	EVEN
STOP BIT:	1 STOP
BAUD RATE:	2400

### PC CONFIGURATION

Kit PK-9200 includes the MS-9200 Programming Utility software on 3-1/2" floppy disk P/N 75298, the Instruction Manual P/N 15677 and the PIM-24 (Printer/PC Interface Module with cable and DB9F/25 connectors).



Figure 2.30: Remote Serial Printer and Computer Connections





### III PROGRAMMING/READ STATUS

The MS-9200 is completely field programmable, and requires no special software skills. Programming may be accomplished in one of three ways:

- The Autoprogram feature - This method is very convenient for quickly bringing the system on-line or for program editing.
- Manual Programming or editing, using the MS-9200 keypad.
- The Off Line Programming feature - This method allows creation of site-specific programs using a DOS-based computer. For programs requiring a large amount of data entry, this method may be preferred. A programming kit (PK-9200) may be ordered for this purpose.

When a programmed system is normal with no active alarms, troubles or supervisories, the 'SYSTEMS ALL NORMAL' screen will be displayed as shown below:



SYSTEMS ALL NORMAL  
10:00 A MON 03/04/96

In order to (1) program the system, (2) read system status, (3) print, (4) edit, or (5) walktest, the ENTER key must first be pressed. After pressing ENTER, the screen shown below is displayed:



1=PROGRAMMING  
2=RD STATUS 3=AC/BAT

1 = Programming: Programming the system may only be accomplished by an authorized user. Before attempting to program the system, place the SW1 Write Protect switch in the down position. SW1 is located on the lower right side of the MS-9200 main circuit board (see page 6). If the switch is in the up 'Write Protect' position while attempting to enter the Programming Mode, the LCD will display the following:



WRITE PROTECT!!!  
PRESS BACKSPACE

In order to program the system, a valid password must first be entered. Once the correct password is entered, the user may select Autoprogram or Program Editing. After programming is completed, return SW1 to the Write Protect position.

*NOTE: There are two programming levels. Program Level 1 is for system configuration in which data relating to device types, zoning, messages, etc. is entered into the system memory. Program Level 2 is where a qualified operator can access features such as Disable, Clear History, Walktest, Time Change and Program Check. For Program Level 2, the SW1 Write Protect switch should remain in the up (Write Protect) position.*

2 = Read Status: Entering Read Status allows the user to read the status of any point/zone in the system plus display or print the history file or print the entire user program. The Read Status feature is NOT password protected. Read Status is explained in Section IV Operating Instructions.

3 = AC/BAT: Entering AC/BAT allows the user to read the battery voltage and AC line voltage. The AC/BAT feature is NOT password protected.

**BATTERY: 24V  
AC LINE: 240V**

Section 3.1 on the following page describes initial programming procedures for a new system. The same procedures are used to modify programming in an existing system. Make certain the SW1 Write Protect switch is in the down position before attempting any Level 1 Programming functions.

### **3.0 Initial Power-up**

Once wiring of addressable devices to the SLC loop is completed, power up the system. Since the addressable devices have not yet been programmed, their LEDs will not flash, the System Trouble LED will be on and the LCD display will alternate between the following two displays:

**TROUBLE IN SYSTEM  
PROGRAM CORRUPTED**

**TROUBLE IN SYSTEM  
NO DEVICES INSTALL**

If the system remains unprogrammed, the piezo will sound after a few minutes. It can be silenced by pressing the Acknowledge/Step switch, but it will continue to resound until the system is programmed.

### 3.1 Programming

Press the ENTER key. The screen below will appear:

1=PROGRAMMING  
2=RD STATUS 3=AC/BAT

To enter the programming mode, press '1'. The display will read as follows:

KEY IN 5 DIGIT  
PASSWORD, THEN ENTER

Entering the Level 1 password (default 00000) will cause the following screen to appear: (Refer to Section 3.2)

0=CLR 1=AUTO 2=POINT  
3=SYS 4=PWORD 5=LOAD

Entering the Level 2 password (default 11111) will cause the following screen to appear: (Refer to Section 3.3)

1=DISABL 2=CLR HIST  
3=WALK 4=TIME 5=CHEK

## Passwords

There are two factory set programming passwords, 00000 and 11111, which will access two different screens as indicated on the previous page. From either of the screens, access to specific system and device programming may be obtained. All programming entries are stored in nonvolatile memory. The factory set passwords can be changed by the user, and a method exists to clear one or both passwords. *Note: For Canadian applications, both passwords must be changed from the factory settings.* If an invalid password is entered, the display shows: 'INCORRECT PASSWORD'. To exit from Programming operations at any time, press the Backspace (Left Arrow) key repeatedly.

## 3.2 Program Change - Level One

When the correct password is entered, the MS-9200 will enter Level One program mode. In this mode, the trouble relay is activated and the System Trouble LED flashes (and cannot be changed to steady). The piezo sounder is off. The following display will appear:



0=CLR 1=AUTO 2=POINT  
3=SYS 4=PWORD 5=LOAD

### 3.2.01 Clear

Pressing '0' will clear all general system programming options as defined in Section 3.2.04 and all programmed addressable devices from the nonvolatile memory of the MS-9200. Before executing the CLEAR command, the display will prompt the user to press ENTER in order to verify the command before the system actually clears programming data. CLEAR is a useful command when the unit is first installed, prior to autoprogramming. *NOTE: It is necessary to 'Autoprogram' after using the clear function.*

### 3.2.02 Autoprogram

Pressing '1' enters the AUTOPROGRAMMING mode. The main purpose of autoprogramming is to allow the installer a fast and easy way to bring the system on-line as quickly as possible. The first time the system is brought on-line, it must be autoprogrammed. *Autoprogram is also the only way to add or delete devices.*

Once autoprogram is selected, the MS-9200 automatically polls all devices installed/wired to the SLC loop. The panel communicates with each individual addressable device and displays the type of device at each address location starting with detectors and then modules.

While autoprogramming the system, the MS-9200 will display the following:



AUTOPROGRAM  
PLEASE WAIT

Verification of each device address and type installed on the SLC may now occur. If information is correct press the ENTER key, if not press the left arrow key to delete. In addition, adjective and noun descriptors plus zone assignments may be added to the display field per device address. If the Reset key is pressed at this time or the panel is allowed to timeout (after 10 minutes), a 'System Corrupted' message will appear. Be certain to step through all devices using the Enter or Left Arrow key.

The first time that autoprogramming is selected, all points installed on the SLC loop are identified. Default device type (monitor, smoke detector, control) and software zone assignments for each device are displayed. On any successive enabling of the autoprogram feature, the LCD will display *only the newly installed, deleted or changed devices on the SLC loop*.

Devices which match the program already in memory are not changed and are not shown to the operator. Devices which do not match the program (not the same address and/or type) are shown to the operator. Devices inadvertently set to the same address are identified, and displayed on the screen.

**I. NEW DETECTORS**

For each new detector, the Autoprogram feature selects default program values and presents the information to the user. A typical example:



where: the 'P' in P01 represents the actual type code (photo) of the detector found at address 01. ('I' represents Ion type detector.)

The adjective and noun fields are blank, but may be user programmed.

**Z00** is the default zone selection meaning 'general alarm' (main circuit board NAC outputs 1 & 2). See Appendix B for Software Zone Assignment.

After the new detector is displayed, press ENTER to accept the default information shown. Alternately, press LEFT CURSOR (the triangle to the left of ENTER) to reject the autoprogram information, and not enter it into memory. In most cases, adjective, noun descriptors and zone assignments will be added by using the following procedure.

The MS-9200 will lead you through the program editing process. A blinking cursor moves through the fields as you press the RIGHT CURSOR key (the triangle to the right of ENTER). After moving into other fields, you may return to a previous field by pressing LEFT CURSOR. Change the blinking fields by pressing the UP CURSOR key, the DOWN CURSOR or by pressing the appropriate numeric key.

Custom words may be entered via the keypad. The alphanumeric operation of the keypad changes a blinking letter in the ADJ and NOUN fields.. For example, to enter the letter R, press the 7 key to step through 7, P, R and S; stop on R; then press the **RIGHT CURSOR** (not ENTER) to move to the next letter position.

To reduce the number of key presses, the user may also select from a library of stored words. The ADJ field library provides five character words selected by the UP cursor or DOWN cursor from the list below.

_____	blanks (default)	FIRST
NORTH		__2ND
SOUTH		__3RD
_EAST		__4TH
_WEST		__5TH
FRONT		FLR_1
CENTR		FLR_2
_REAR		FLR_3
UPPER		FLR_4
LOWER		FLR_5
_MAIN		RM___

The ADJECTIVE field may be loaded from the library list above, and then modified letter-by-letter if desired.

Pressing the UP or DOWN cursor keys steps through the library. Once the UP or DOWN keys are pressed, the blinking cursor moves to the last character of the ADJECTIVE field, assuming that the user will next want to move beyond this field.

Pressing a key on the 12-key pad changes the letter indicated by the blinking cursor. Any alphanumeric character may be entered.

Pressing the RIGHT or LEFT cursor key moves the blinking cursor one letter right or left.

When the RIGHT cursor key is pressed with the blinking cursor on the last letter of the ADJECTIVE label, the cursor will move to the first letter of the NOUN field.

Altering the NOUN field is done in a similar way. Use the UP or DOWN cursor keys to step through the NOUN library (shown below).

\_\_\_\_\_ (all blanks - default)  
\_BASEMENT\_  
\_BOILER\_RM  
\_CLASSROOM  
\_CLOSET\_\_\_\_  
\_CORRIDOR\_  
\_ELECT.\_RM  
\_ELEVATOR\_  
\_ENTRANCE\_  
\_FLOOR\_\_\_\_  
\_GARAGE\_\_\_\_  
\_HALLWAY\_\_\_\_  
\_HVAC-ROOM  
\_KITCHEN\_\_\_\_  
\_LOBBY\_\_\_\_  
\_OFFICE\_\_\_\_  
\_PATIENT\_\_\_\_  
\_RESTROOM\_  
\_ROOM\_\_\_\_\_  
\_STAIRWAY\_  
\_STOREROOM  
\_WING\_\_\_\_\_  
\_ZONE\_\_\_\_\_

In addition, the user may use the Recall/Increment function at any time when the cursor is on the first letter of the ADJ or NOUN field as follows:

- If the Zero is pressed, a '0' is placed in the first letter position.
- If the Zero key is then pressed a second time with no intervening key actions, the entire ADJECTIVE field is replaced with the field entered for the previous device programmed, and the cursor moves to the last character of the field (Recall function). The Recalled ADJECTIVE or NOUN field may now be changed letter by letter.
- If the Zero key is pressed again with no other intervening key actions, and the last character in the field is a number 0-9, the number is incremented by one. If the last character is a letter, it changes to a '0'. If the last character goes from 9 to 0, and the characters to the left of the last character are also numbers, they are also incremented (overflow).
- The above increment function may be repeated with each press of the Zero key.

As an example, the user could quickly enter 'FLR\_3\_ROOM\_305' as follows:

- 1) The cursor is on the first letter of the ADJ field. Press the Zero key twice to display 'FLR3'.
- 2) With the cursor on the first letter of the NOUN field, press the Zero key twice to recall the display 'ROOM304'. The cursor automatically jumps from the first to the last letter of the noun field.
- 3) With the cursor on the last letter of the NOUN field, press the Zero key again to increment the room number to 305.
- 4) Press the Right arrow cursor to advance to the Zone field.
- 5) Select a zone number from 00 to 56. Z00 (default zone) is the general alarm zone. Z01 through Z56 may be selected to link software zones. Only zones Z01 through Z16 will be displayed on the optional ZDM-16F LED module.

To load the addressable device's program into memory at any time, press the ENTER key. After pressing ENTER, autoprogram displays the next new detector. If a detector had been previously entered into memory, but is missing (no answer), the display shows the following:

```
PROGRAM SMOKE DET P01
NO ANSWER  DELETE?
```

If ENTER is pressed, the device is deleted from memory and autoprogram displays the next new device. If the LEFT CURSOR is pressed, the program is unchanged, and the next new device is displayed.

After all new detectors are presented for editing, the autoprogram feature displays the modules on the SLC loop starting with the device found at the lowest address.

## II. MONITOR MODULE AUTOPROGRAM

Monitor Module Autoprogram is similar to Detector Autoprogram. When a new monitor module is presented, a typical display might be:

```
PROGRM MONITOR M01
<ADJ><NOUN>      Z00
```

The major program editing for monitor modules is the selection of the Type Code on the first line. To change this selection, use the UP and DOWN cursor keys as the entire field blinks. The default selection is monitor, as shown in the screen above. Note that selection of a type code *may change the functional operation of the addressable device*.

### TYPE CODE LABEL

MONITOR  
PULL BOX  
HEAT DET  
SMOKE ZON  
WATERFLOW  
SUPERVISY  
TAMPER\_SW

ACK\_SW\_  
SILENC SW  
RESET SW  
DRILL\_

### SPECIAL FUNCTION

NONE (DEFAULT)  
NONE  
NONE  
NONE  
NONE  
CAUSES NON SILENCEABLE ALARM  
BECOMES SUPERVISORY POINT (SEE SECTION IV, OPERATION)  
BECOMES SUPERVISORY POINT (SEE SECTION IV, OPERATION)  
NONE (BLANK LABEL)  
FUNCTIONS LIKE ACKNOWLEDGE SWITCH  
FUNCTIONS LIKE SILENCE SWITCH  
FUNCTIONS LIKE RESET SWITCH  
FUNCTIONS LIKE DRILL SWITCH

Follow the same procedure as described in Section I New Detectors, for editing of the ADJECTIVE and NOUN fields.

The default zone selection is Z00 (main circuit board NAC outputs 1 & 2) and may be set to Z01 through Z56 if desired. See Appendix B Software Zone Assignment.

### III. CONTROL MODULE AUTOPROGRAMMING

A typical control module Autoprogram screen would be:



Control modules default to zone Zone 00 (general alarm). All type code options are silenceable except Relay and Strobes. The selection of control module type codes may change their function.

Select the type code from the library list below. Use the cursor keys as described in Section I New Detectors.

<u>TYPE CODE</u>	<u>SPECIAL FUNCTION</u>
1 CONTROL	NONE (DEFAULT) Silenceable
2 BELL CKT	Silenceable
3 HORN CKT	Silenceable
4 SOUNDERS	Silenceable
5 _____	(BLANK LABEL) Silenceable
6 RELAY	IGNORE OPEN CIRCUIT (Non-silenceable)
7 STROBES	Non-silenceable

Select an adjective descriptor from the library list shown in Section I New Detectors. Use the cursor keys as described in Section I.

Control modules may be assigned to a maximum of three software zones. (See Appendix B). Zone Z00 represents general alarm. All control modules are assigned to Zone Z00 upon initial power up.

#### 3.2.03 Point Edit

While displaying the Program Level One Menu screen (see Section 3.2), pressing '2' allows for editing of the point (addressable device) descriptor screens. These screens show the device type, the device address, adjective and noun field descriptors and the software zone locations that the point (addressable device) is assigned to. Point editing is performed *after autoprogramming* and may be done at any time, except during an alarm condition. The display shows:



For example, select Detector address 3 program edit by pressing the \* key (\* = detector), followed by numeric key 3, followed by ENTER. Select Module address 3 program edit by pressing the # key (# = module), followed by the numeric key 3, followed by ENTER. If there is no device installed at this address, the panel displays the next higher address where a device is installed. After editing is complete, and ENTER is pressed, the display returns to the above menu. *Rather than reentering the next point number, the user may press the UP or DOWN key to display the next lower or higher existing point.* Using software P/N 73750 or greater, to edit NAC1 or NAC2, press the \* key, then the # key, then press '1' for NAC 1 or '2' for NAC 2. Select either 'BELL\_CKT' for silenceable functionality or 'STROBE' for nonsilenceable functionality. Use the system edit menu described in Section 3.2.04 to select coding. Coding is only possible if the NAC is programmed as 'BELL\_CKT'. The point display formats and the method of editing are described in Section 3.2.02, Autoprogramming.



### 3.2.04 System Edit

The System Edit function is selected by pressing '3'. The system edit screen appears as shown below for software releases prior to P/N 73750. This software does not support the LCD-40 Annunciator:

VF=N SI=N AS=N PS=N  
CD=N AN=N ST=4 REM=N

Use the Up and Down arrow keys to scroll through the choices for each option and the Left and Right arrow keys to move from option to option.

There are eight system function options for software releases prior to P/N 73750. The factory default selections and user option selections are shown below:

<u>FUNCTION</u>	<u>DEFAULT</u>	<u>SELECTION</u>
VF = Alarm Verification	(N)one	(Y)120 seconds
SI = Silence Inhibit	(N)one	(Y)60 seconds <sup>1</sup>
AS = Auto-Silence	(N)one	(Y)10 minutes <sup>1</sup>
PS = Pre-signal	(N)one	(Y)3 minutes with 15 second Acknowledge <sup>1</sup>
CD = Bell Code 1	(M)arch Time	(N) = None
<i>Note: Bell 2 is fixed steady</i>		(T) = Temporal
		(C) = California
AN = Annunciators	(N)one	(Z) = 56 Zones
		(ZU) =56 Zones Annunciator with UDACT-F <sup>2</sup>
		(P) = 198 Points
		(PU) = 198 Points Annunciator with UDACT-F <sup>2</sup>
ST = SLC loop style	(4) = Style 4	(6) = Style 6
REM = Alarm/Trouble Reminder	(N)o	(Y)es = Sound onboard piezo every 15 seconds during alarm and every 2 minutes during trouble after acknowledge or silence key has been pressed.

<sup>1</sup>Requires prior approval of Local Authority Having Jurisdiction.

<sup>2</sup>When the UDACT-F has a fault, this entry allows the FACP to display 'DACT Trouble' on the LCD display and printer hardcopy. The history file will also be updated with this information. For zone annunciation, up to 56 zones, use AFM Series Annunciators or LDM Series Annunciators. For 198 point annunciation, use the LDM Series Annunciators.

The system edit screen appears as shown below for software P/N 73750 or greater. This software is required to support the LCD-40 Annunciator:

V=N I=N A=N P=N C=N  
A/U=N L/P=N S=4 R=N

There are nine system function options for software P/N 73750 or greater. The factory default selections and user option selections are shown below:

<u>FUNCTION</u>	<u>DEFAULT</u>	<u>SELECTION</u>
V = Alarm Verification	(N)one	(Y)120 seconds
I = Silence Inhibit	(N)one	(Y)60 seconds <sup>1</sup>
A = Auto-Silence	(N)one	(Y)10 minutes <sup>1</sup>
P = Pre-signal	(N)one	(Y)3 minutes with 15 second Acknowledge <sup>1</sup>
C = Bell Code	(N)one	(M) = March Time (T) = Temporal (C) = California
A/U = Annunciators with or without UDACT-F	(N)one	(Z) = 56 Zones (ZU) =56 Zones Annunciator with UDACT-F <sup>2</sup> (P) = 198 Points (PU) = 198 Points Annunciator with UDACT-F <sup>2</sup>
L/P = LCD-40 or Printer/PC in use	(N)one	L = LCD-40 installed (requires DIM-485) P = Printer or local PC installed (requires PIM-24)
S = SLC loop style	(4) = Style 4	(6) = Style 6
R = Alarm/Trouble Reminder	(N)o	(Y)es = Sound onboard piezo every 15 seconds during alarm and every 2 minutes during trouble after acknowledge or silence key has been pressed.

<sup>1</sup>Requires prior approval of Local Authority Having Jurisdiction.

<sup>2</sup>When the UDACT-F has a fault, this entry allows the FACP to display 'DACT Trouble' on the LCD display and printer hardcopy. The history file will also be updated with this information. For zone annunciation use AFM Series Annunciators or LDM Series Annunciators. For 198 point annunciation, use the LDM Series Annunciators.

### 3.2.05 Password Change

While displaying the Program Menu, press '4' to change either of two passwords. One high level password, defaulted to 00000, allows for point and system programming. A second lower level password, defaulted to 11111, allows for status changes such as: (1) disable points/zones (2) clear history file, (3) walk test enable, (4) time and date set and (5) program check. Pressing '4' will display:

\* ,NNNNN, E=LEVEL 1 PW  
# ,NNNNN, E=LEVEL 2 PW

Select the password to change by typing \* or #, then enter the new password. As the new program or status password is entered it is displayed. When ENTER is pressed, the display reads "PRESS ENTER IF OK, NNNNN = NEW PROGRAM PW". After ENTER is pressed, the new password is stored in EEPROM memory and the program returns to the program change screen. If BACKSPACE is entered, the password remains unchanged and the program returns to the program change screen.

### 3.2.06 LOAD

While displaying the Program Menu, program selection '5' sets up the MS-9200 for transfer of its application database from/to a DOS-based computer. This may be used to save the program that exists in an MS-9200 for security and future service reasons; or may be used to transfer a program created off-line to the MS-9200. Refer to Document# 15677 for more information. When the Load option is selected, the following screen will be displayed:



CONNECT COMPUTER NOW  
RUN PROGRAM FROM PC

The LEFT CURSOR may be used to return to the program change screen. The PC connects to the EIA-232 printer interface (instructions provided with the Upload/Download software kit). Continue to press the Backspace key (left cursor) to return to the main program screen.

### 3.3 Program Change - Level Two

While the MS-9200 system is normal with no active alarms, troubles or supervisories, the screen shown below will be displayed:



SYSTEMS ALL NORMAL  
10:00 A MON 03/04/96

To access the programming mode, the ENTER key must be pressed. After pressing ENTER, the following screen is displayed:



1=PROGRAMMING  
2=RD STATUS 3=AC/BAT

Pressing '1' will cause the following screen to appear:



KEY IN 5 DIGIT  
PASSWORD, THEN ENTER

Enter the Level 2 password (default = 11111) then press the ENTER key to access Programming Change Level Two. The screen below will appear:

1=DISABL 2=CLR HIST  
3=WALK 4=TIME 5=CHEK

From this screen, the available function choices include point DISABLE, CLEAR HISTORY, WALKTEST, SET TIME and CHECK programming.

### 3.3.01 Disable

Pressing '1' displays the following screen:

DISABLE/ENABLE  
PRESS \*/#, AA, ENTER

Press the \* key to display detectors, the # key to display modules, followed by the device address, then the ENTER key. A typical display is shown below:

ENABLE SMOKE DET P01  
NORTH BASEMENT Z01

A point is then displayed on the screen similar to a Point Edit display but with the current status label (ENABLE) blinking. The current status label may show: NORMAL, TROUBL, DISABL, ALARM, ACTIVE, PROGRM, TEST 01, ON, OFF. The status label can be changed to DISABL or back to its present status by pressing the UP or DOWN keys. The disable status is entered/stored in memory by pressing ENTER. The display then returns to the DISABLE/ENABLE screen shown above. The operator may then enter a new point number, or may press UP/DOWN to bring up the next lower/higher address point. *The disabling of initiating devices that are in alarm or control points that are ON occurs after the RESET key is pressed.*

All disabled points will scroll on the LCD display and the system will remain in trouble until all programmed points are enabled.

### 3.3.02 Clear History

Pressing '2' displays the following screen:

ENTER TO CLEAR HIST.  
BACKSPACE TO ESCAPE

Press the ENTER key to clear the 500-event History file. Press the left cursor key (Backspace) to exit without clearing the History file. *Caution: Pressing Enter will clear all History events associated with this panel. Care should be taken to ensure this is the appropriate action.*

### 3.3.03 Walk Test

If '3' is pressed, followed by ENTER, the following is displayed:

WALK TEST 1-SILENT  
2-PULSE SOUNDERS

Press '1' to perform a silent walktest with all sounding devices, control modules and the bell 1 and bell 2 outputs OFF. Select '2' to perform an audible walktest which sounds all silenceable control modules and bells 1 and 2 (if programmed as 'BELL\_CKT' as explained in Section 3.2.03) output during walktest. (Disabled NAC outputs will not activate during Walktest). Each alarm and trouble condition (short and open) will be printed in real time and stored in the 500 event history buffer. After pressing either '1' or '2', the screen shown below will appear:

ENTER START WALKTEST  
BACKSPACE TO STOP

If ENTER is pressed, the second line goes blank, and the unit is in Walk Test mode. Walk test may be stopped at any time by pressing Backspace, returning the unit to the main screen. A one hour time-out automatically returns the system to normal operation.

#### Shorted/Alarm Condition

When in Walk Test, the panel responds to each new alarm and activates its programmed control outputs for four seconds, if those control outputs have been programmed for silenceable activation. It also stores each alarm in the history file and printer with a "TEST XX" status label. XX is a count of the number of times a device with this address has been tested. Note that this is a convenient way to identify two detectors that are erroneously set to the same address. A complete Walktest will cause a TEST 02 indication for the addresses to which both devices are set and no TEST report for the address that one of the devices should have been set to.

Note that if the system under test includes one or more enabled M302 monitor modules, the following may apply:

If the M302 monitor module is used for a supervised, 2-wire smoke zone, alarming any monitor module in the system will result in the activation of programmed control outputs for an additional eight seconds or less. This is caused by the temporary removal of 24 VDC resettable power from the M302. The M302 reports this loss of power as an open condition in addition to the alarm condition.

#### Open Condition

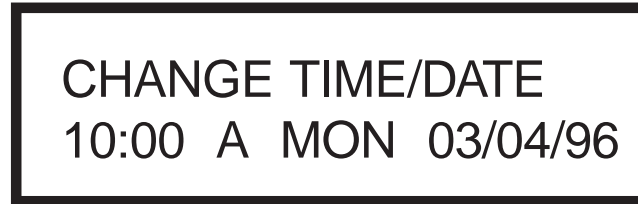
300 Series devices as well as both main circuit board NACs are monitored for fault conditions during Walktest Mode. When a new trouble condition occurs, it activates all control modules programmed for WALK test and Bell Circuit 1, then shuts them off after an 8 second interval (4 seconds longer than alarms). The trouble status label is "TEST T".

While in Walk Test, the trouble relay is on, and the System Trouble LED flashes (as in all of Program and Status change operations). The alarm relay is not activated. The LCD displays the following:

ENTER START WALKTEST

### 3.3.04 Set Time/Date

If '4' is pressed, the following is displayed:



The first digit of the hours is flashing and may be changed with the numeric pad. The RIGHT CURSOR moves to the next digit and the UP/DOWN cursor selects (A)M or (P)M and day of the week. Pressing the ENTER key stores the time and date and returns to the level 2 main screen.

### 3.3.05 Check

Program selection '5' performs a check on software zone assignments. The MS-9200 looks for output devices assigned to a software zone that does not contain any input devices (detectors, monitor modules). If multiple devices fail the check, the UP/DOWN keys are used to step through the list of devices. The user *must* return to point editing to correct any errors.

*NOTE: The system continues monitoring alarm conditions during all Programming and Read Status operations with the exception of Walktest.*

At the completion of system programming, Switch SW1 (Write Protect switch) should be set to the Write Protect position to prevent inadvertent changes to programmed features. Slide the switch to the up position to select the Write Protect feature. See Figure 2.23 for the location of SW1.

# IV OPERATING INSTRUCTIONS

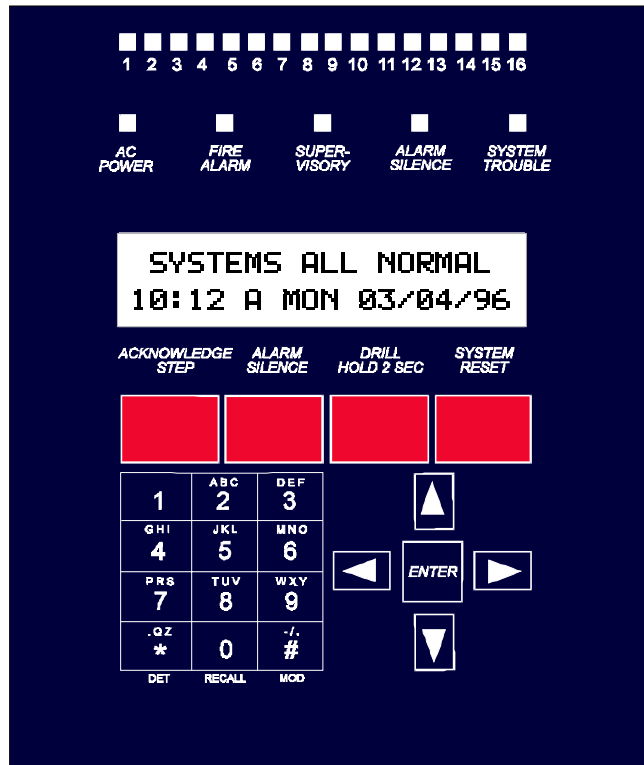


Figure 4.1: The MS-9200 Membrane Switch Panel

## 4.0 Control Switches

### ACKNOWLEDGE/STEP

The Acknowledge/Step key silences the piezo sounder and changes all flashing LEDs to steady. Only one press is necessary regardless of the number of new alarms, troubles or supervisory signals. When the piezo is silenced, an 'ACKNOWLEDGE' message is sent to the printer and the history file. Multiple active events are scrolled on the display at a three second rate.

ACKNOWLEDGE also automatically sends a 'SILENCE PIEZO' command to the LCD-40, AFM and LDM annunciators.

When more than one event exists, the first press of the Acknowledge/Step switch silences the piezo and changes all flashing LEDs to steady. The second press of the switch stops the scrolling and holds the event on the display for 1 minute. Subsequent pressing of the switch 'steps' through each active event.

### ALARM SILENCE

The Alarm Silence switch performs the same functions as ACKNOWLEDGE/STEP. In addition, if an alarm exists, it turns off all silenceable circuits and causes the ALARM SILENCE LED to turn on. It also sends an 'ALARM SILENCED' message to the printer, the history file and the LCD-40. A subsequent new alarm will resound the system.

### DRILL HOLD 2 SEC

When the DRILL switch is held for two seconds (time required to prevent accidental activations), the MS-9200 turns on both main panel NAC outputs and all silenceable circuits (all control modules/Notification Appliance circuits that are programmed silenceable) and turns off the ALARM SILENCE LED. The 'MANUAL EVACUATE' message is shown on the LCD display. The same message is sent to the printer and history file. The Silence key operates on *silenceable* NAC outputs only.

## SYSTEM RESET

Pressing the System Reset switch turns off all control modules and Notification Appliance Circuits, temporarily turns off resettable power to 4-wire detectors, causes an 'All Systems Normal' message to be displayed on the LCD, and stores 'System Reset' in the printer and history file. It also turns on all LEDs, piezo, and LCD display segments as long as SYSTEM RESET is held (lamp test). Any alarm or trouble that exists after System Reset will resound the system.

## 4.1 LED Indicators

The six LED indicators on the front panel operate as follows:

### • AC POWER

This is a green LED which illuminates if 240 VAC power is applied to the system.

### • FIRE ALARM

This is a red LED that flashes when one or more alarms occur. It illuminates steadily when the ACKNOWLEDGE or SILENCE switch is pressed. The Alarm LED turns off when the SYSTEM RESET switch is pressed.

### • SUPERVISORY

This is a yellow LED that flashes when one or more supervisory conditions occur, such as a sprinkler valve tamper condition. It illuminates steadily when the ACKNOWLEDGE or SILENCE switch is pressed. It turns off when SYSTEM RESET is pressed.

### • ALARM SILENCE

This is a yellow LED that turns on after the ALARM SILENCE key is pressed (preceded by a fire alarm condition). It turns off when the ALARM ACTIVATE or SYSTEM RESET switch is pressed.

### • SYSTEM TROUBLE

This is a yellow LED that flashes when one or more trouble conditions occur. It stays on steady when the ACKNOWLEDGE or SILENCE switch is pressed. The LED turns off when all trouble conditions are cleared. This LED will also illuminate if the microprocessor watchdog circuit is activated.

## 4.2 Normal Operation

With no alarms or troubles in the system, the display message is "SYSTEMS ALL NORMAL" along with the current time and date as shown below. To set the time and date, see Section 3.3.04.



SYSTEMS ALL NORMAL  
10:00 A MON 03/04/96

The MS-9200 performs the following functions at regular intervals while in normal mode:

- Polls all devices on SLC loop. Checks for valid reply, alarms, troubles, etc.
- Monitors AC input voltage and battery capacity.
- Refreshes LCD display and updates time.
- Scans keyboard.
- Performs detector auto test.
- Tests memory.
- Updates/Reads EIA-485 communications bus.



### 4.3 Trouble Operation

With no alarms, the detection of a trouble in the system will cause the piezo to sound, the System Trouble LED to flash, and the trouble relay to activate. A message will appear on the LCD display indicating the trouble condition. The same message is sent to the printer and history file, along with time and date.

**Addressable Smoke Detectors:** For addressable Ion or Photoelectric smoke detectors, the following is a typical message that could appear on the LCD display for a detector in trouble.

```
TRBL_# SMOKE DET P01
<ADJ> <NOUN>      Z00
```

The information displayed in the first line in the example above provides the following information:

- The type of event - in this example TRBL indicates Device Trouble.
- The Specific Device Trouble - the # symbol will be replaced by a digit representing a specific trouble condition. (Refer to the list of Specific Device Troubles below).
- Type of device - in this example SMOKE DET indicates smoke detector.
- Point type and address - in this example P01 indicates Photoelectric detector assigned to address 01.

The information displayed in the second line in the example above provides the following information:

- <ADJ> - user programmed adjective descriptor from library list or custom entry (five characters max.).
- <NOUN> - user programmed noun descriptor from library list or custom entry (ten characters max.).
- Zone - zone to which the point is assigned.

The # symbol in the display will be replaced by a digit that represents the Specific Device Troubles as listed below:

1 = Invalid Reply:

An Invalid Reply may be due to: (1) incorrect pulse width received from a detector, (2) no answer from a detector due to either a complete device failure or removal from the SLC loop, or (3) an incorrect identification code received, i.e. a photoelectric detector replaced by an ion detector or vice-versa.

2 = Maintenance Alert:

A Maintenance Alert indicates that a detector has been within 80% of its alarm threshold for 24 hours, indicating that the detector needs cleaning.

3 = Fail Automatic Test:

Fail Automatic Test indicates that a detector's sensing chamber and electronics (which are tested for normal safe operation every two hours) has failed.

**Monitor and Control Modules:** The following is a typical message that could appear on the LCD display for monitor modules and control modules in trouble.

```
TRBL_# MONITOR M01
<ADJ> <NOUN>      Z00
```

The information displayed in the first line in the previous example provides the following information:

- The type of event - in this example TRBL indicates Device Trouble.
- The Specific Device Trouble - the # symbol will be replaced by a digit representing a specific trouble condition. (Refer to the list of Specific Device Troubles below).
- Type of device - in this example MONITOR indicates monitor module.
- Point type and address - in this example M01 indicates monitor module assigned to address 01.

The information displayed in the second line in the previous example provides the following information:

- <ADJ> - user programmed adjective descriptor from library list or custom entry (five characters max.).
- <NOUN> - user programmed noun descriptor from library list or custom entry (ten characters max.).
- Zone - zone to which the point is assigned.

The # symbol in the display will be replaced by a digit that represents the Specific Device Troubles as listed below:

1 = Invalid Reply:

An Invalid Reply may be due to: (1) incorrect pulse width received from a module, (2) no answer from a module due to either a complete device failure or removal from the SLC loop, or (3) an incorrect identification code received, i.e. a monitor module replaced by a control module or vice-versa.

2 = Short Circuit Control Module:

A Short Circuit exists across a control module's Notification Appliance Circuit (NAC).

3 = Open Circuit Monitor/Control Module:

An Open Circuit exists on a control module's Notification Appliance Circuit (NAC) or the monitor module's Initiating Device Circuit (IDC).

Pressing the Acknowledge switch will cause the piezo to silence and the System Trouble LED to go on steady. This occurs regardless of the number of troubles, alarms and supervisory events active in the system (block acknowledge). When Acknowledge is pressed, and at least one new alarm or trouble exists in the system, the ACKNOWLEDGE message is sent to the printer and history file.

If the trouble clears, either before or after ACKNOWLEDGE, the CLEAR TROUBLE message is sent to the printer. For example:

**CLR TRBL\_# SMOKE DET P01 <ADJ><NOUN> ZONE # TIME and DATE**

If all troubles clear and there are no supervisory or fire conditions active in the system, the system returns to normal operation status, and the SYSTEMS ALL NORMAL message is shown on the LCD display and stored in the history and printer files. Trouble restore occurs even if the troubles were never acknowledged (auto restore).

If ALARM SILENCE is pressed when only troubles exist, it will have the same effect as ACKNOWLEDGE/STEP. The ALARM SILENCE LED will not be illuminated unless there was also an alarm in the system.

If multiple trouble conditions exist in the system, they will be scrolled on the LCD display automatically at a three second rate. *If a combination of alarms, troubles and/or supervisory conditions occur in the system simultaneously, only the alarms are scrolled on the display.* If the ACKNOWLEDGE/STEP key is pressed, the display stops on the present item for one minute, or until the ACKNOWLEDGE/STEP key is pressed again. As the ACKNOWLEDGE/STEP key is pressed, the MS-9200 displays events in the following priority order:

**Alarms, in order of address  
Supervisory, in order of address  
Troubles, in order of address**

## 4.4 Alarm Operation

Alarm operation is similar to trouble operation, but with the following differences:

- The Piezo produces a steady sound, not pulsed
- The System Alarm (not Trouble) LED flashes
- ALARM: device name, type, and address are displayed
- Alarms latch and *are not allowed to clear automatically*
- Alarms activate software zones (control by Event Logic) if so programmed
- Timers (Silence Inhibit, Auto Silence, Trouble Reminder) are started
- Alarms activate the general alarm relay and zone Z00 (NAC1 and 2)
- The Trouble Relay is not activated

A typical alarm display would be:

```
ALARM: PULL STATION M02  
<ADJ><NOUN> ZONE #
```

## 4.5 Supervisory Operation

Supervisory operation is similar to alarm operation, but with the following differences:

- The Piezo is a warbling sound
- The Supervisory LED (not Alarm) flashes
- The Display Status label is ACTIVE
- Supervisory Relay is activated
- Silenced alarms are not resounded
- Timers are not started
- The alarm relay is not activated

A typical supervisory event would display:

```
ACTIVE TAMPER M02  
<ADJ><NOUN> ZONE #
```

Note that, like alarms, supervisory signals latch and can be assigned to a software zone. Supervisory alarms do not cause resound as do other alarm conditions. Open circuits in supervisory wiring are processed by the MS-9200 the same way as other trouble conditions.

## 4.6 Notification Appliance Circuit (NAC) Operation

There are two Notification Appliance (bell) Circuits on the MS-9200. For software releases prior to P/N 73750, NAC 1 is programmable and factory defaulted to general alarm, silenceable and March Time coding operation. NAC 2 is not programmable and is fixed as general alarm, nonsilenceable and may not perform coded functions.

For software releases 73750 or greater, both NAC 1 and NAC 2 are programmable. Both NACs may be either silenceable or nonsilenceable and may be programmed as steady or coded operations. Coded operation includes March Time, Temporal or California types. Refer to Section 4.10 for additional information on coding.

## 4.7 Control-By-Event Operation

Each addressable detector and monitor module can be assigned to one software alarm zone. Control modules may be assigned to a maximum of three software zones. A General alarm zone (Z00) may be listed for output (control) points, but it is not necessary to list Z00 for input points, as this is the default zone. Z00 is not activated by supervisory points.

When an input device (detector, M300 series modules) alarms and is not disabled, it activates all software zones assigned to it. An output device (control module or Notification Appliance Circuit) that is not disabled is turned on when any of the software zones to which it is mapped become active.

## 4.8 Detector Functions

### MAINTENANCE ALERT

Each detector is monitored by the control panel for its maintenance status. If a detector is within 80% of its alarm threshold for a 24 hour period, a 'maintenance alert' message will be displayed automatically signaling that the detector needs cleaning.

### AUTOMATIC TEST OPERATION

An automatic test of each detector is performed every two hours. The detector's sensing chamber and electronics are functionally tested for normal, safe operation. A trouble message is displayed upon failure of this test. System Reset clears this trouble.

### TYPE CODE SUPERVISION

The MS-9200 monitors hardware device type codes (CP300, SD300, SD300T, M300, M301, M302, and C304) at slow intervals. Mismatch of any type code, compared to the system program, will cause a device trouble.

### SYSTEM ALARM VERIFICATION

The panel may be programmed to perform alarm verification. Alarm verification applies to detectors only. Refer to Section 4.12 for a description of the Alarm Verification Timer.

## 4.9 Time Functions

### REAL TIME CLOCK OPERATION

The MS-9200 includes a crystal time base clock that provides time of day, date, and day of week. Time is displayed as 12 hour time with month/day/year, and is stored in RAM. If both AC and battery power are lost, the time must be reset.

## 4.10 Coded Operation - Notification Appliance (Bell) Circuits 1 and 2

Shown below are the pulse rate outputs via NAC 1 or NAC 2 when coded operation is selected. Note that software releases prior to P/N 73750 only allow coding on NAC 1. Releases 73750 or greater allow coded functions on both NAC 1 and NAC 2.

**CONTINUOUS** NO PULSE

**MARCH TIME** PULSES AT 120PPM.

**TEMPORAL CODE** PULSES TEMPORAL CODE (0.5 sec. On, 0.5 sec. Off, 0.5 sec. On, 0.5 sec. Off, 0.5 sec. On, 1.5 sec. Off).

**CALIFORNIA CODE** 10 sec. On, 5 sec. Off

## 4.11 Presignal

Presignal is used to delay output activation (control modules and NACs) while allowing for visual verification by a person. Once a detector or monitor module triggers an alarm, the onboard piezo sounds immediately, but the Notification Appliance (bell) Circuits are not activated for 15 seconds. During this time, if the acknowledge switch is pressed, the piezo is silenced and the Notification Appliances will not activate for up to 3 minutes. After 3 minutes, the Notification Appliances will activate if the source of the alarm is not cleared. This does not affect monitor modules programmed as waterflow or supervisory. Presignal operation requires the approval of the local Authority Having Jurisdiction.

## 4.12 Special System Timers

### SILENCE INHIBIT TIMER (NONE OR 60 SECONDS)

This option, if selected, prevents the ALARM SILENCE switch from functioning for 60 seconds after an alarm. A new alarm during the initial 60 seconds will cause the timer to restart with a new 60 seconds. Silence Inhibit operation requires the approval of the local Authority Having Jurisdiction.

### AUTO SILENCE TIMER (NONE OR 10 MINUTES)

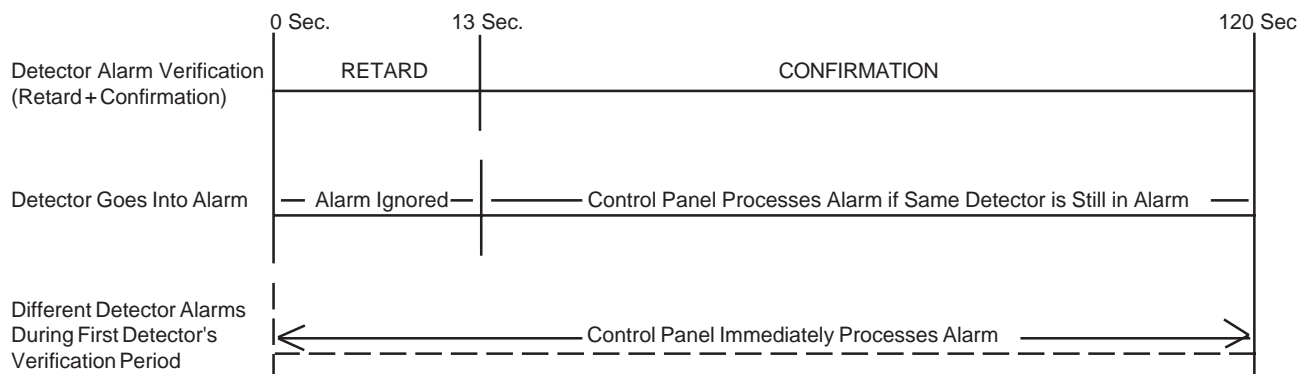
If Auto Silence is selected, the Notification Appliances will be silenced automatically after ten minutes of activation. Pressing DRILL will restart the timer with a new 10 minutes. Auto Silence operation requires the approval of the local Authority Having Jurisdiction.

### TROUBLE REMINDER

If selected, this feature causes a reminding 'beep' every 15 seconds during an alarm (after the Silence switch is pressed) and a 'beep' every two minutes during a trouble condition after the Acknowledge or Silence switch is pressed. The 'beeps' from the onboard piezo will occur until the alarm or fault is cleared.

### ALARM VERIFICATION (NONE OR 2 MINUTES)

If alarm verification is selected, an addressable smoke detector's alarm is ignored for a retard time of 13 seconds and the detector's alarm condition is automatically reset. There will be no alarm indication at the FACP during the Retard period. A confirmation period of 1 minute and 47 seconds follows, during which a subsequent alarm from the same detector will cause the panel to immediately activate the appropriate outputs and indicate the alarm condition at the FACP. If a different detector alarms any time during the first detector's verification period, the panel will immediately activate all appropriate outputs and indicate the alarm condition at the FACP. If no additional detector alarms occur within 2 minutes of the first alarm (13 second retard plus 1 minute and 47 second confirmation), the timer resets and the panel is ready to verify any new detector alarms which may occur.



### WATERFLOW CIRCUITS OPERATION

If an alarm exists from a monitor module point that has a Waterflow type code, the ALARM SILENCE switch will not function.

### DISABLE/ENABLE OPERATION

Input points which are disabled do not cause an alarm or any CBE (Control-By-Event) activity. Disabled output points are held in the off state. All disabled points are treated as if they were in trouble except the status label displayed is **DISABL**.

## 4.13 Style 6 Operation

If the SLC is wired and programmed for Style 6, and a single fault occurs, the control panel will detect the fault and drive both ends of the line, fully recovering from the fault. The panel latches the trouble and displays it until the System Reset switch is pressed. The display shows **STYLE 6** trouble type.

## 4.14 Read Status

Read Status functions do not require a password. *The MS-9200 will continue to provide fire protection while in read status mode.* Read status may be entered while in alarm or trouble. If a new alarm or trouble occurs during these functions, the Read Status is aborted to prevent confusion.

### READ STATUS ENTRY

The operator presses the ENTER key, and the LCD display shows:



```
1=PROGRAMMING
2=RD STATUS 3=AC/BAT
```

The operator presses 2, and the display shows:



```
DISPLAY POINT=*/#, AA
HISTORY=1 PRINT=2
```

From this display, an operator may select one of three choices:

- To DISPLAY POINT status, the type of device to be read must first be identified by pressing the (\*) key for a detector or the (#) key for a module. The two digit device address is keyed in next, followed by the ENTER key.
- To DISPLAY ZONE status, press the (\*) key, then press the (\*) key again. Next, key-in the zone number (1-56) and press ENTER. The UP and DOWN cursor keys are used to view the next or previous zone.
- To DISPLAY SYSTEM PARAMETERS, press the (\*) key then press the (\*) key again followed by ENTER.
- To DISPLAY BELL CIRCUIT status, press the (\*) key, followed by the (#) key, then the digit 1 or 2, then ENTER.
- To display the 500-event HISTORY file on the LCD, press the 1 key, then ENTER. The UP and DOWN Arrow keys are used to step through the entries in the file.
- To PRINT PROGRAM CONTENTS and CURRENT SYSTEM STATUS or HISTORY FILE, press the 2 key, then ENTER. A new Menu appears which prompts to press 1 to print Program/Status or 2 to print History file.

During this and all subsequent operations except print operations, a two minute timer is started that will return to the previous display if no key is pressed. Each key press restarts the two minute timer. Press of the left CURSOR (backspace) deletes the previous entry. If there is no entry, it will abort the Read Status operation and return to the previous display. System Reset will also abort the Read Status.

## DISPLAY POINT

DISPLAY POINT operations display *addressable device status* on the LCD display. After the status of the device is displayed, the UP key may be used to display the status of the next highest addressable device, and the DOWN key to display the status of the previous addressable device. The sequence of point display is Detector points 01-99, Module points 01-99, NAC bell circuits 01-02, System parameters, and Zones 1-56.

A typical Read Status display is as follows:



```
NORMAL SMOKE DET P01
WEST HALLWAY Z56
```

**NORMAL** is the present status (could be ALARM, TRBL\_#, DISABL, etc.)

**SMOKE(DET)** is the device type, **P** indicates that this is a Photoelectric detector (could be **I** if Ionization, PULL BOX, HORN CKT, etc.), and **01** is the device address.

**WEST HALLWAY** is the custom label programmed for this device.

**Z56** is the assigned software zone.

If the point is not installed, a Read Status command to that point will result in a **NOT INSTALLED** message on the display.

### READ HISTORY:

The MS-9200 has a 500-event history buffer. Stored events include Point Status, System Troubles, and ACKNOWLEDGE/STEP, ALARM SILENCE, DRILL and SYSTEM RESET key presses. All events are recorded with the time and date. History events are stored in volatile memory, therefore, removal of primary AC power and secondary battery power will clear the history buffer. To clear the History file without removing power, see Section 3.3.02. To view events in the history file, use the Up and Down arrow keys to step through the events.

### PRINT PROGRAM:

All user programmed options including device types, software zone assignments and system parameters may be printed. The printout also includes current system status. See Section 2.16 for instructions on connecting a printer.

### PRINT HISTORY:

The entire 500-event history file may be printed using the PRINT HISTORY feature. Refer to Section 2.16 for instructions on connecting a printer.

# APPENDIX A: SUPPLY CALCULATIONS

## 1. The AC Branch Circuit

The MS-9200 requires connection to a separate dedicated AC branch circuit (240 VAC), which must be labeled **FIRE ALARM**. This branch circuit must connect to the line side of the main power feed of the protected premises. No other equipment may be powered from the fire alarm branch circuit. The branch circuit wire must run continuously, without any disconnect devices, from the power source to the fire alarm control panel. Overcurrent protection for this circuit must comply with Article 760 of the National Electrical Code as well as local codes. Use #14 AWG wire with 600 volt insulation for this branch circuit.

**Table A-1: AC Branch Circuit Requirements** @240 VAC

Use Table A-1 to determine the total amount of current, in AC amps, that must be supplied to the system.

Unit Type	Number of Units		Current Draw (amps)		Total Current per Device
MS-9200	1	X	1.2	=	1.2
R45-24E Charger	[ ]	X	0.5	=	
<b>Total AC Branch Current Required</b>				=	amps



## 2. The Main Power Supply

The MS-9200 provides regulated power for operating the fire alarm control panel, operating external devices, and operating the standby battery. The power for operating external devices is limited. Use Table A-2A (standby or non-alarm) and Table A-2B (alarm) to determine if external loading is within the capabilities of the MS-9200 power supply.

Concerning smoke detectors: Refer to the manufacturer's data sheet packaged with each smoke detector to find the standby and alarm current draws to use in the tables of this Appendix. Be sure to power detectors from TB4, Terminals 5 and 6.

**Table A-2A: Regulated Load in Standby @24 VDC**

*External Devices connected to TB4 only*

Device Type	# of Devices		Standby Current (Amps)	=	Total Current (Amps)
Main Circuit Board	1	X	0.08	=	0.08
RTM-8F	[ ] one max.	X	0.009	=	
ACM-8RF	[ ]	X	0.030	=	
ZDM-16F	[ ] one max.	X	0.00005	=	
AFM-16ATX AFM-32AX	[ ] one max.	X	0.04	=	
AEM-16ATF AEM-32AF	[ ]	X	0.002	=	
AFM-16ATF AFM-32AF	[ ]	X	0.04	=	
AFM-16AF	[ ]	X	0.025	=	
UDACT-F	[ ] one max.	X	0.04	=	
LDM-32F	[ ]	X	0.04	=	
LDM-E32F	[ ]	X	0.002	=	
LCD-40	[ ]	X	0.054	=	
4-Wire Smoke Detector	[ ]	X	[ ]	=	
Power Supervision Relay	[ ]	X	0.025	=	
CP300	[ ]	X	0.00015	=	
SD300	[ ]	X	0.00015	=	
SD300T	[ ]	X	0.0002	=	
M300	[ ]	X	0.0002	=	
M301	[ ]	X	0.0002	=	
M302	[ ]	X	0.007	=	
BG-10LX	[ ]	X	0.0002	=	
C304	[ ]	X	0.0002	=	
I300	[ ]	X	0.0004	=	
<b>Sum Column for Standby Load</b>				<b>=</b>	<b>Amps</b>

**Notes:**

- 1) TB4, Terminals 1 and 2: Non-Regulated, 24 VDC, 2.5 amps.
- 2) TB4, Terminals 3 and 4: Regulated, Filtered 24 VDC +/- 5% 120Hz ripple @10 mV<sub>RMS</sub>
- 3) TB4, Terminals 5 and 6: Regulated, Filtered 24 VDC +/- 5% 120Hz ripple @10 mV<sub>RMS</sub>
- 4) TB4, Terminals 3 and 4; are nonresettable auxiliary power, 300 mA.
- 5) TB4, Terminals 5 and 6 are resettable (smoke detector power), 300 mA.
- 6) Refer to Current Limitations on next page.

**Table A-2B: Regulated Load in Alarm @24 VDC**  
*External Devices connected to TB2 and TB4*

Device Type	# of Devices		Current (Amps)		Total Current (Amps)
Main Circuit Board	1	X	0.168	=	0.168
RTM-8F	1	X	0.146 <sup>4</sup>	=	
ACM-8RF	[ ]	X	0.158 <sup>10</sup>	=	
ZDM-16F	1	X	0.08 <sup>5</sup>	=	
AFM-16ATX AFM-32AX	[ ]	X	0.056 <sup>6</sup>	=	
AEM-16ATF AEM-32AF	[ ]	X	0.018 <sup>6</sup>	=	
AFM-16ATF AFM-32AF	[ ]	X	0.056 <sup>6</sup>	=	
AFM-16AF	[ ]	X	0.065 <sup>5</sup>	=	
UDACT-F	[ ]	X	0.075 <sup>7</sup>	=	
LDM-32F	[ ]	X	0.056	=	
LDM-E32F	[ ]	X	0.018	=	
LCD-40	[ ]	X	0.054	=	
4-Wire Smoke Detector	[ ]	X	_____	=	
Power Supervision Relay	[ ]	X	_____	=	
Addressable Devices	Max.Draw All Devices	X	0.2	=	0.2
Notification Appliances	[ ]	X	_____	=	
Sum Column for Alarm Load				=	Amps <sup>9</sup>

Refer to next page for battery calculations using Total Standby and Total Alarm Loads.

**Notes:**

1) *Current limitations of terminals:*

- TB4, Terminals 1 and 2 = 2.50 Amps.
- TB4, Terminals 3 and 4 = 0.300 Amp.
- TB4, Terminals 5 and 6 = 0.300 Amp.
- TB1 and TB2, Any one circuit = 2.50 Amps.

2) *Total current draw of terminals listed above cannot exceed:*

- 3.6 Amps - With Standard Transformer (4000TAE) installed alone.
- 6.0 Amps - With both Standard Transformer (4000TAE) and optional Transformer (XRM-24E) installed.
- Total current from TB4, Terminals 3 and 4, 5 and 6 not to exceed 0.600 amperes.
- Total System power is 6.6 amps max.

3) *M302 Monitor Module current limit at 90 mA in alarm.*

4) *All RTM-8F Relays activated.*

5) *All 16 ZDM-16F LEDs on.*

6) *All Annunciator LEDs on.*

7) *UDACT-F actively making phone call to Central Station. If the normally open contact is used, current consumption increases to 100mA.*

8) *LDM-32F with LEDs on.*

9) *This column must not exceed 6.6 amps.*

10) *All eight ACM-8RF Relays activated on a single module.*

## BATTERY CALCULATIONS

Use the Total Standby and Alarm Load Currents calculated in Tables A-2A and A-2B for the following battery calculation.

Standby Load Current (Amps) [    ]	X	Required Standby Time Hours (24 or 60 Hours) [    ]
Alarm Load Current (Amps) [    ]	X	Required Alarm Time in (i.e. 5 min. = 0.08 [    ]
Add Standby and Alarm Load for Required Ampere Hour Batt		
Multiply by the Derating Factor of 1.2		
Total Ampere Hours (AH) Required		

**NOTE:**

- 1) 7 AH battery can be located in the MS-9200 Backbox.
- 2) 12 AH and 17 AH batteries require the Fire•Lite BB-17F Battery box.
- 3) 20 AH to 55 AH batteries require the Fire•Lite R45-24E Charger for housing and charging batteries.

# APPENDIX B: SOFTWARE ZONES

Setup and configuration of an addressable system is quite different than a conventional system. In a conventional system, assignment of input devices (detectors, pull stations, heat detectors, etc.) to zones is straight forward. Wiring is direct from clearly marked panel terminals to any device assigned to a particular zone. Connection of output devices (horns, bells, strobes, etc.) in a conventional system is done by direct wiring of the output device to terminals marked 'bell'.

With addressable systems, the same pair of wires is used to connect to all addressable input and output devices. Communications between the panel and all addressable devices takes place over one pair of wires originating from the panel. *Software programming is used to configure the system, versus direct wiring.* Zone assignment is created via software means, hence the term 'software zones'.

Setup of an MS-9200 software zone is straightforward. Any zone may have a minimum of one and a maximum of 99 addressable input devices. Each detector is automatically assigned to a general alarm output. A zone may also have a minimum of one and a maximum of 99 addressable output devices.

Use the charts on the following pages to help in 'zoning' the system. Note that monitor and control modules make up one group of 99 addresses. It is critical that addresses of detectors are not duplicated and that monitor and control addresses are not duplicated.

In the following example, photo detectors (SD300) at addresses 01 and 02, along with a monitor module (M300) at address 01 and control modules (C304) at addresses 03, 04 and 05 have been assigned to zone 1. Zone 2 consists of ion detectors (CP300) at addresses 03 and 04, monitor module (M301) at address 02 and control modules (C304) at addresses 03, 06 and 07. Zone 3 consists of two photo detectors (SD300) at addresses 05 and 06 plus one ion detector (CP300) at address 07 and control modules (C304) at addresses 03, 08 and 09.

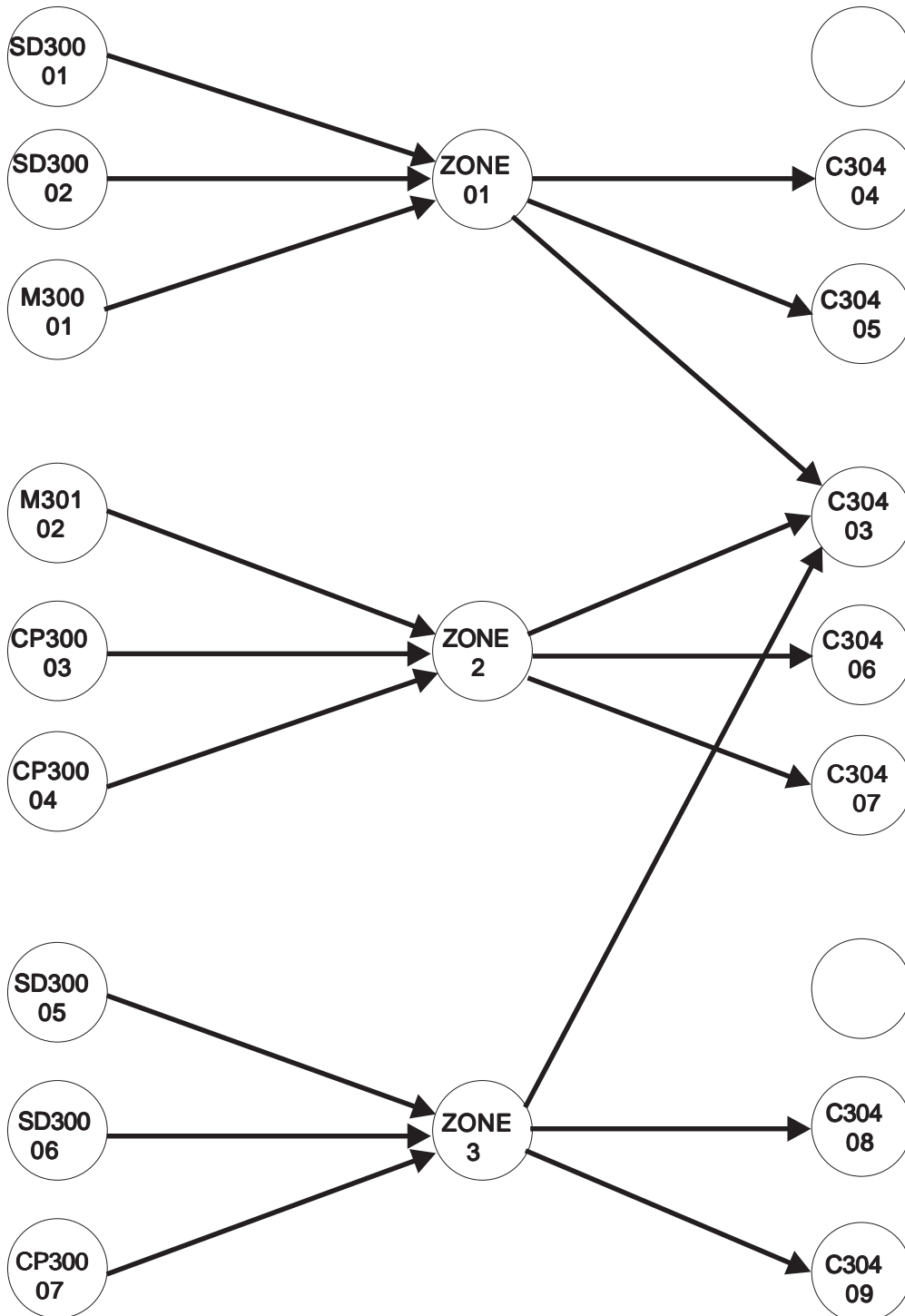
This example points out some of the key assignment features of the MS-9200. Addresses of detectors are not duplicated. Addresses of monitor and control modules are not duplicated. The control module at address 03 is assigned to the maximum three software zones (provides for floor above and floor below). Detectors and monitor modules are assigned to one software zone.

Take care to properly plan the installation prior to installing any devices.

# FOLLOWING IS A ZONING EXAMPLE

## Correlations - Inputs and Outputs to Zones

INPUT DEVICES                      ZONES                      OUTPUT DEVICES



DETECTOR				ZONE
ADDRESS	DEVICE TYPE	ZONE NUMBER	ADJ (Up to 5 Characters) NOUN (Up to 10 Characters)	ADD F
01	SD300	1	FIRST HALL	5
02	SD300	1	ELEV. LOBBY	5
03	CP300	2	2ND FLOOR	5
04	CP300	2	ROOM 210	5
05	SD300	3	3RD FLOOR	5
06	SD300	3	MEZZANINE	5
07	CP300	3	MECH. ROOM	5
08				5
09				5
10				6
11				6
12				6
13				6
14				6
15				6
16				6
17				6
18				6
19				6
20				7
21				7
22				7
23				7
24				7
25				7
26				7

**MONITOR/CONTROL MODULE**

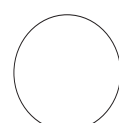
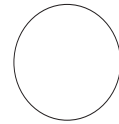
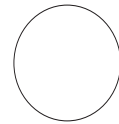
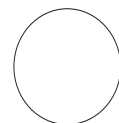
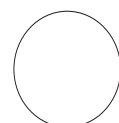
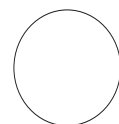
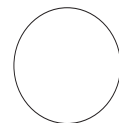
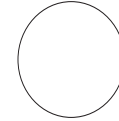
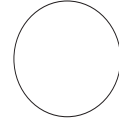
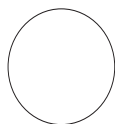
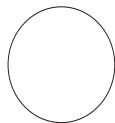
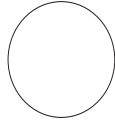
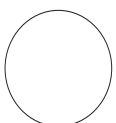
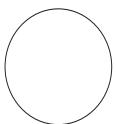
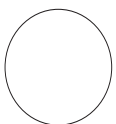
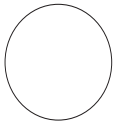
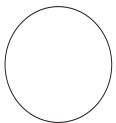
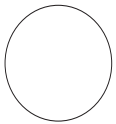
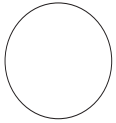
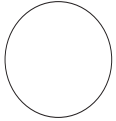
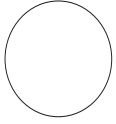
ADDRESS	DEVICE TYPE	ZONE NUMBER	ADJ (Up to 5 Characters) NOUN (Up to 10 Characters)	ADDR
01	M300	1	WEST HALL	51
02	M301	2	EAST STAIRWELL	52
03	C304	1,2,3	2ND FLOOR	53
04	C304	1	1ST FLOOR	54
05	C304	1	EAST HALL	55
06	C304	2	ELEV. LOBBY	56
07	C304	2	MEZZANINE	57
08	C304	3	3RD FLOOR	58
09	C304	3	MECH. ROOM	59
10				60
11				61
12				62
13				63
14				64
15				65
16				66
17				67
18				68
19				69
20				70
21				71
22				72
23				73
24				74
25				75

# Correlations - Inputs and Outputs to Zones

**INPUT DEVICES**

**ZONES**

**OUTPUT DEVICES**





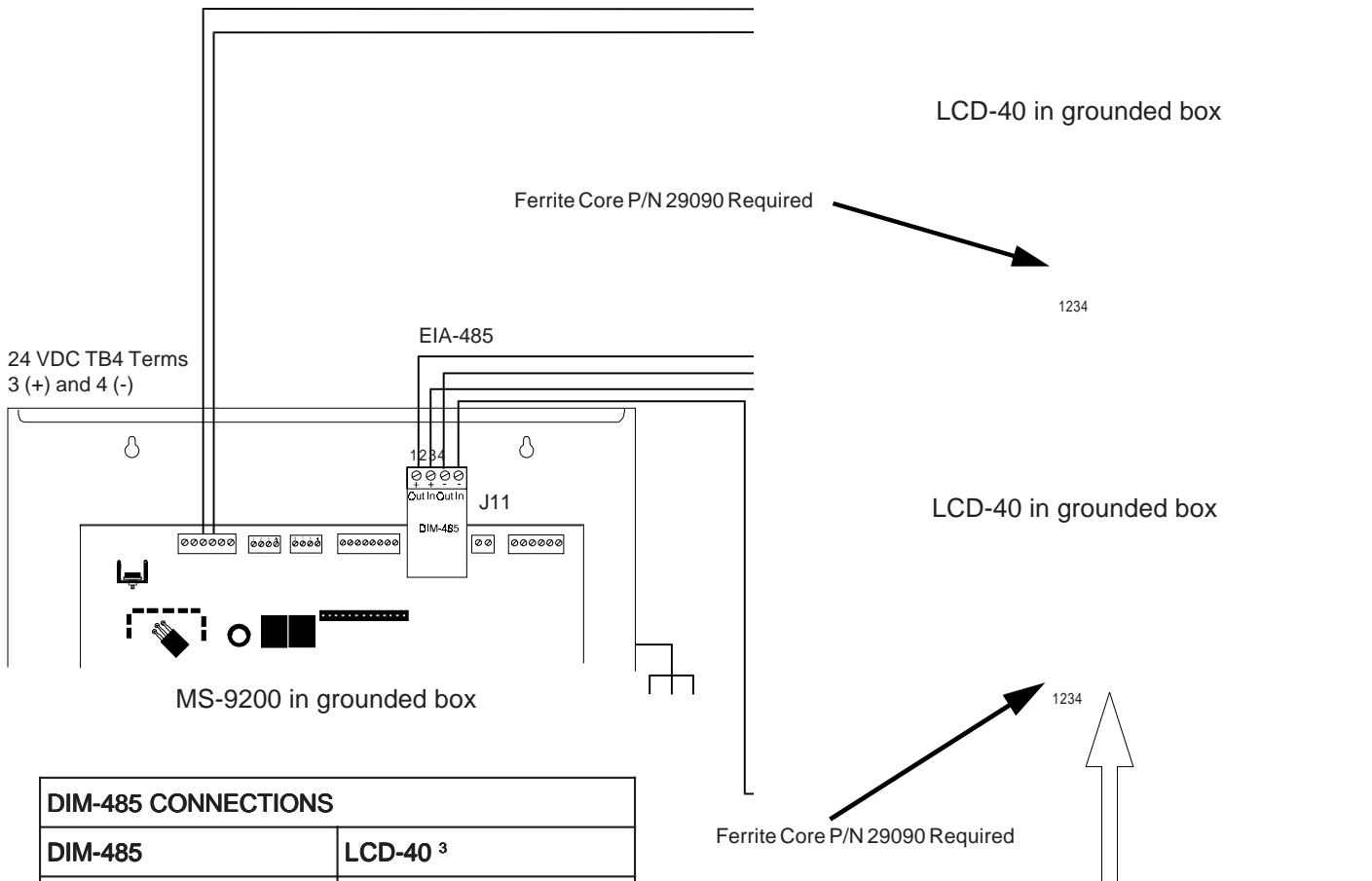
DETECTOR				ZONE
ADDRESS	DEVICE TYPE	ZONE NUMBE	ADJ (Up to 5 Characters) NOUN (Up to 10 Characters)	ADD
01				5
02				5
03				5
04				5
05				5
06				5
07				5
08				5
09				5
10				6
11				6
12				6
13				6
14				6
15				6
16				6
17				6
18				6
19				6
20				7
21				7
22				7
23				7
24				7
25				7
26				7

MONITOR/CONTROL				MODULE
ADDRESS	DEVICE TYPE	ZONE NUMBER	ADJ (Up to 5 Characters) NOUN (Up to 10 Characters)	ADD
01				5
02				5
03				5
04				5
05				5
06				5
07				5
08				5
09				5
10				6
11				6
12				6
13				6
14				6
15				6
16				6
17				6
18				6
19				6
20				7
21				7
22				7
23				7
24				7
25				7
26				7

# APPENDIX C: LCD-40 Annunciator Wiring

The following drawing illustrates the wiring of two LCD-40 Remote Annunciators to an MS-9200 FACP. A maximum of 32 LCD-40s may be connected to a single control panel. The EIA-485 wiring must pass through a Ferrite Core in each LCD-40. The illustration shows power supplied to the annunciators by the MS-9200. For system applications requiring greater than the 300 ma of nonresettable power the MS-9200 can supply, or for remote locations, use the Fire•Lite FCPS-24FE Field Charger Power Supply.

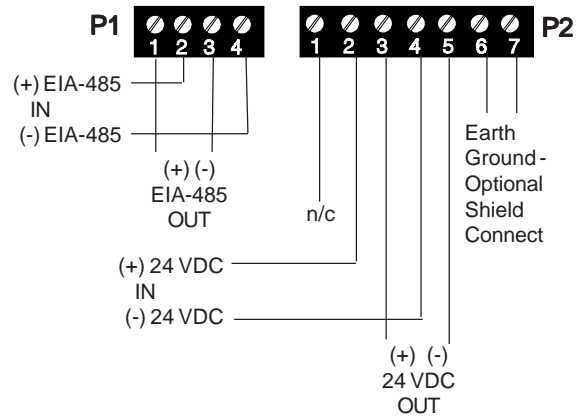
The DIM-485 interface module is required when using the LCD-40. Insert the plastic standoff, supplied with the DIM-485, into the hole located near the J11 connector on the top right side of the MS-9200 main circuit board. (Note that older MS-9200 circuit boards do not have a hole near J11, thus preventing the insertion of the standoff). Align the connector on the DIM-485 board with J11 on the MS-9200 main circuit board and align the hole on the DIM-485 with the standoff inserted into the main circuit board. Carefully seat the DIM-485 connector on the main circuit board J11 connector and press to seat the DIM-485 on the standoff.



DIM-485 CONNECTIONS	
DIM-485	LCD-40 <sup>3</sup>
Terminal 1 - OUT (+)	P1 Terminal 2
Terminal 2 - IN (+)	P1 Terminal 1 <sup>2</sup>
Terminal 3 - OUT (-)	P1 Terminal 4
Terminal 4 - IN (-)	P1 Terminal 3 <sup>2</sup>

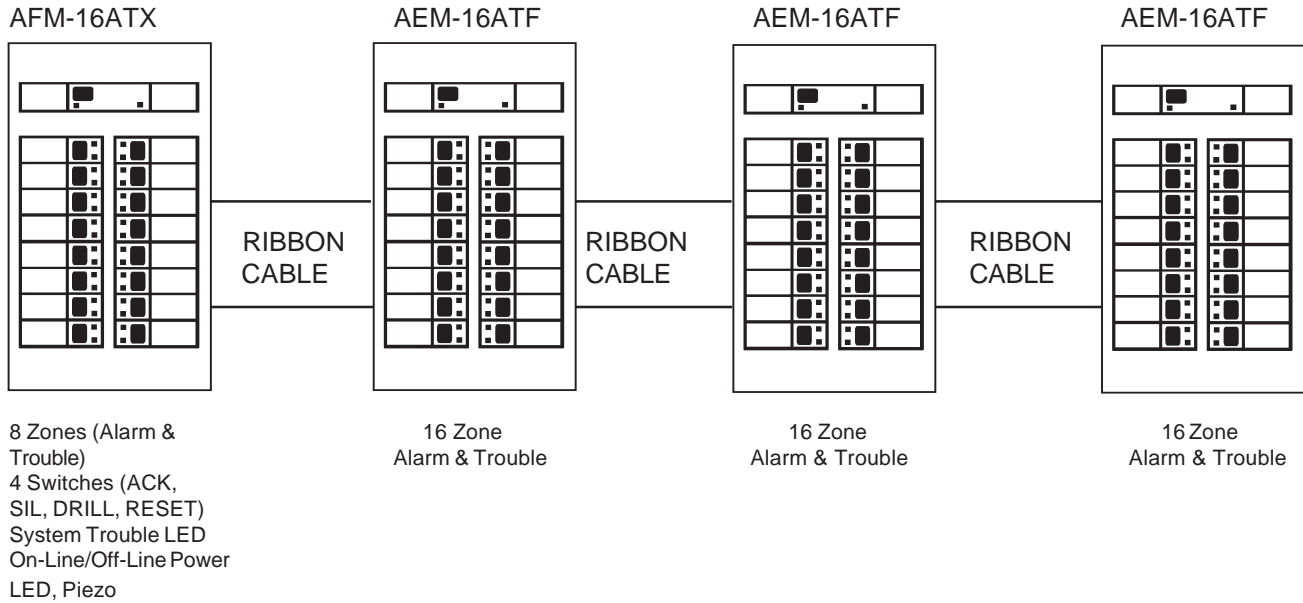
**Notes:**

- 1) The above table shows terminal to terminal wiring between the DIM-485 and one LCD-40.
- 2) If more than one LCD-40 is installed, the wiring to the DIM-485 In (+) Terminal 2 and In (-) Terminal 4 will be from the Out terminals of the last installed LCD-40.
- 3) The LCD-40 must have the two supplied R120 (120 ohm) resistors installed across the In Terminals 2 & 4 and Out Terminals 1 & 3. These resistors are required for impedance matching.
- 4) Refer to the LCD-40 Technical Manual Document #50327 for detailed wiring information.



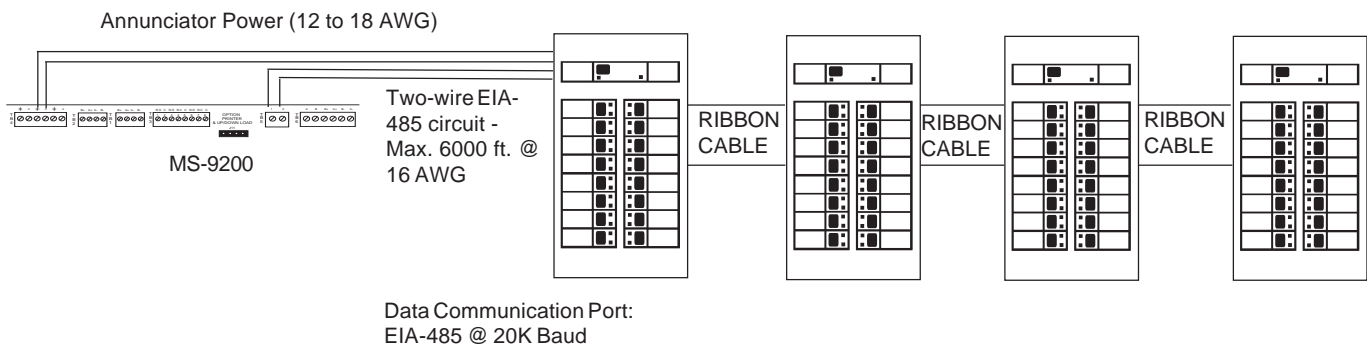
# APPENDIX D: AFM and LDM Series Annunciator Wiring

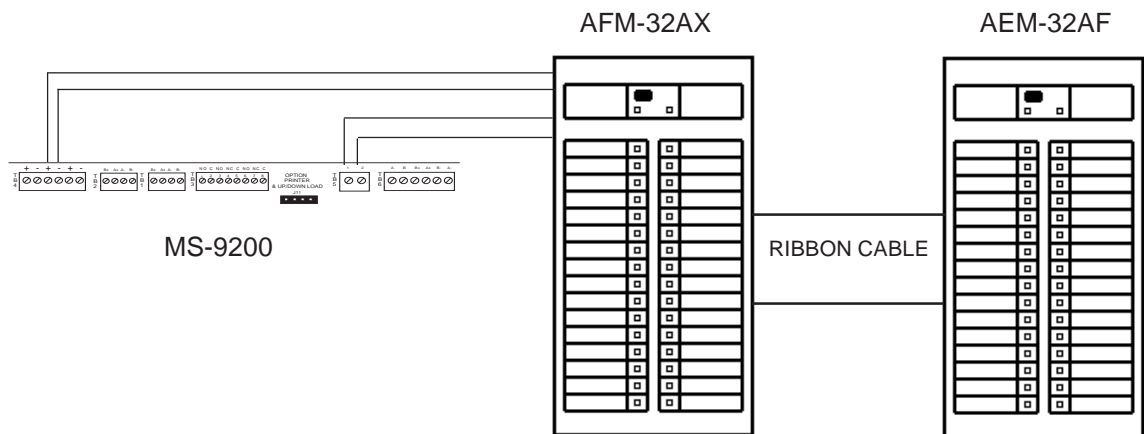
The following drawings illustrate the various configurations which may be wired utilizing AFM Series annunciators. LDM Series annunciators may be used in a similar manner. All drawings show power supplied to annunciators by the MS-9200. For system applications requiring greater than the 300 ma of nonresettable power the MS-9200 can supply, use the Fire•Lite FCPS-24FE Field Charger Power Supply.



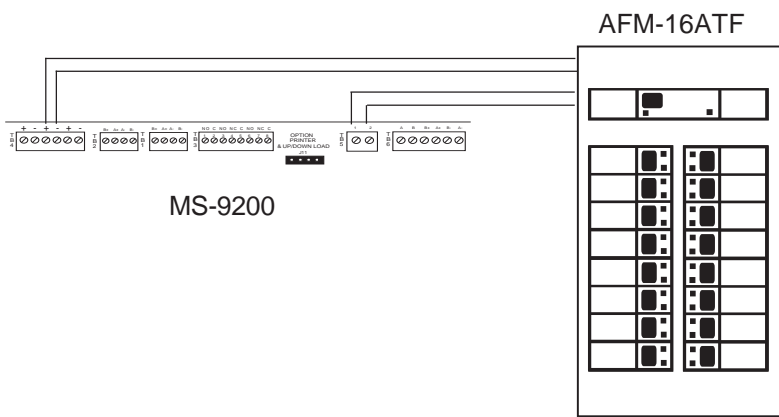
The above configuration provides: 56 Zones of Alarm and Trouble indication, Remote Acknowledge/Step, Alarm Silence, Drill, and System Reset keys, System Supervisory, AC fail, and Trouble indications. Use AKS-1F keyswitch to prevent unauthorized actuation of control switches.

Refer to the AFM Manual for further details.



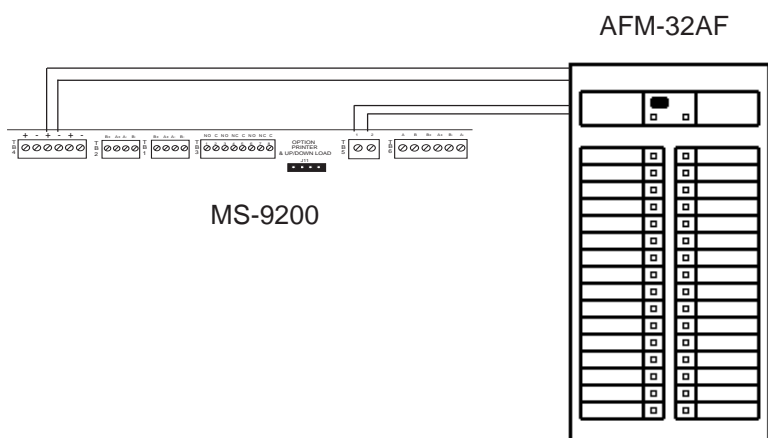


The configuration shown above provides: 56 Zones of alarm indication, a system Trouble LED, an On Line/ Power LED, local piezo, and a Local Silence/Acknowledge switch.



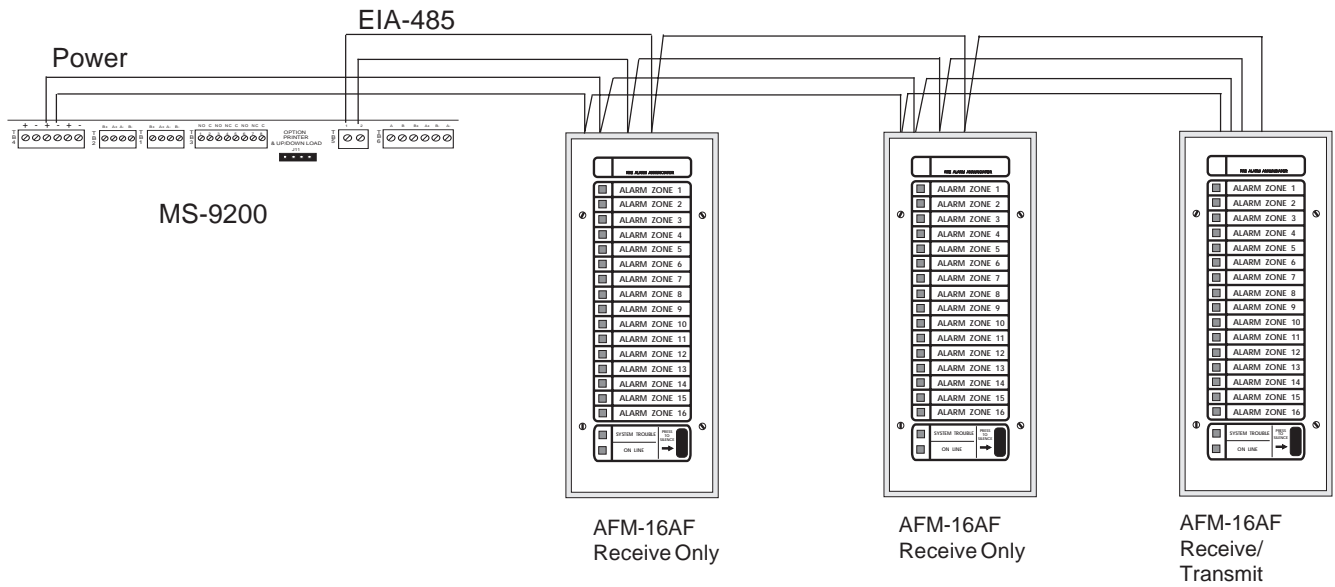
This configuration provides 16 Alarm and Trouble LEDs, System Trouble LED, On Line/Power LED, Local Silence/Acknowledge, Drill, and Reset remote switches, and piezo.

ONLY ONE PER SYSTEM.



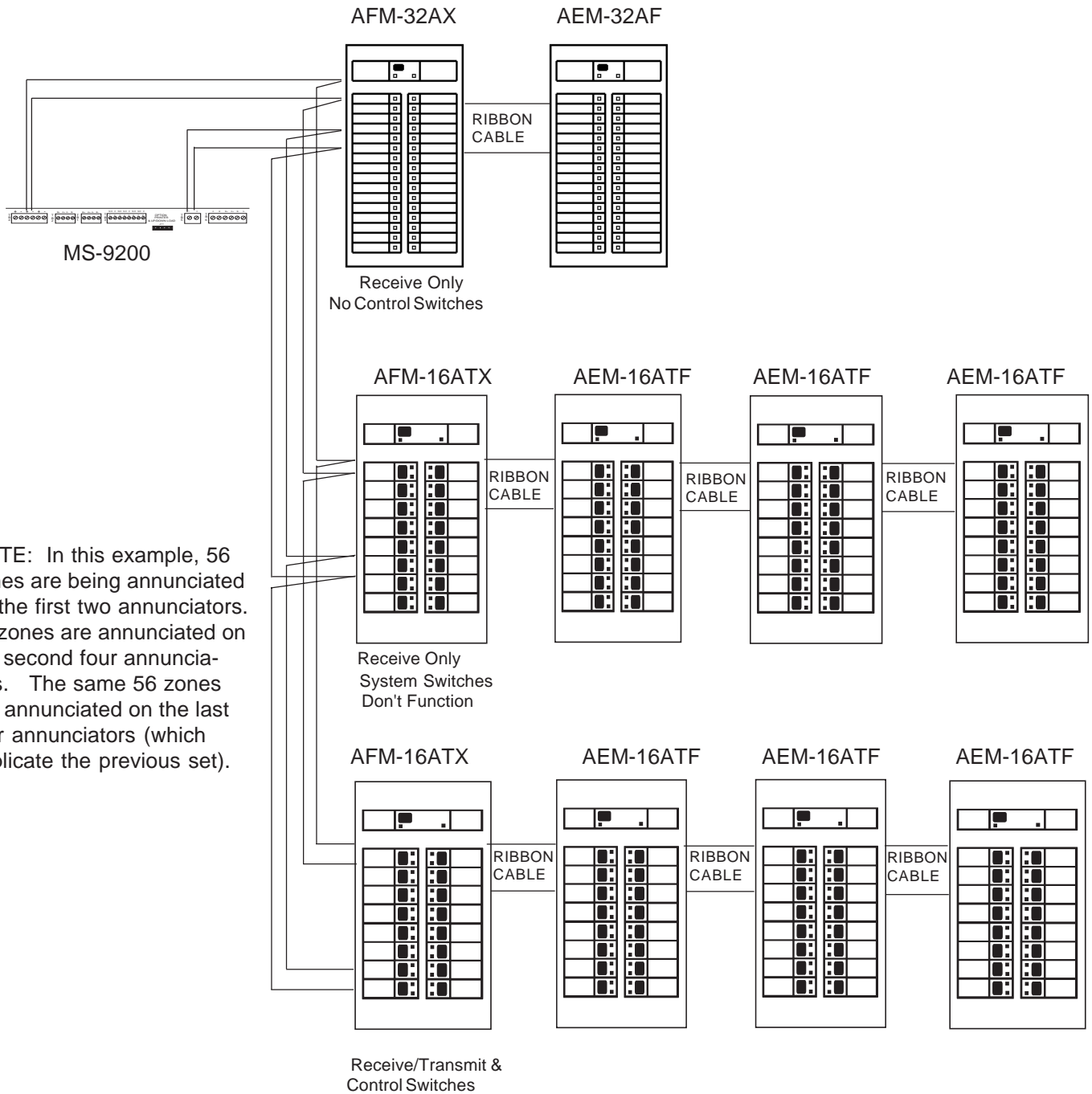
This configuration provides 32 Alarm LEDs, On Line/Power LED, System Trouble LED, and Local Silence/Acknowledge switch.

ONLY ONE PER SYSTEM



The configuration shown above provides: 16 red Alarm LEDs, System Trouble LED, On Line/Power LED, Local Silence/Acknowledge switch, and piezo. All AFM-16AF annunciators will show the same information.

# 56 Zone Annunciator Configuration



# APPENDIX E: NFPA STANDARD-SPECIFIC REQUIREMENTS

The Fire-Lite MS-9200 has been designed for use in commercial, industrial, and institutional applications and meets the requirements for service under the National Fire Protection Association (NFPA) Standards outlined in this Appendix. The minimum system components required for compliance with the appropriate NFPA standard are listed below.

**MS-9200 Control Panel** containing the main control board, cabinet (backbox and door), main supply transformer and power supply.

**Batteries** (refer to Appendix A for Standby Power Requirements).

**Initiating Devices** - connected to one of the control panel's Initiating Device Circuits.

**Notification Appliances** - connected to the control panel's Notification Appliance Circuit or via a control module.

The following additional equipment is needed for compliance with the NFPA 72-1993 standards listed below:

**NFPA 72-1993 Fire Alarm Systems for Central Station Service (Protected Premises Unit) and Remote Station Service**

MS-5012—for connection to a compatible listed Central Station DACR or Protected Premises Receiving Unit. This unit must be installed as outlined in Figure E-1.

OR

UDACT-F may be installed as illustrated in Section II.

**NFPA 72-1993 Auxiliary Fire Alarm System**

RTM-8F Relay-Transmitter Module for connection to a compatible listed Local Energy Municipal Box. This unit must be installed as outlined in Figure E-2.

**NFPA 72-1993 Remote Station Fire Alarm System**

RTM-8F Relay-Transmitter Module for connection to the Fire-Lite RS82 Remote Station Receiver. See Figure E-3 for installation instructions for this unit

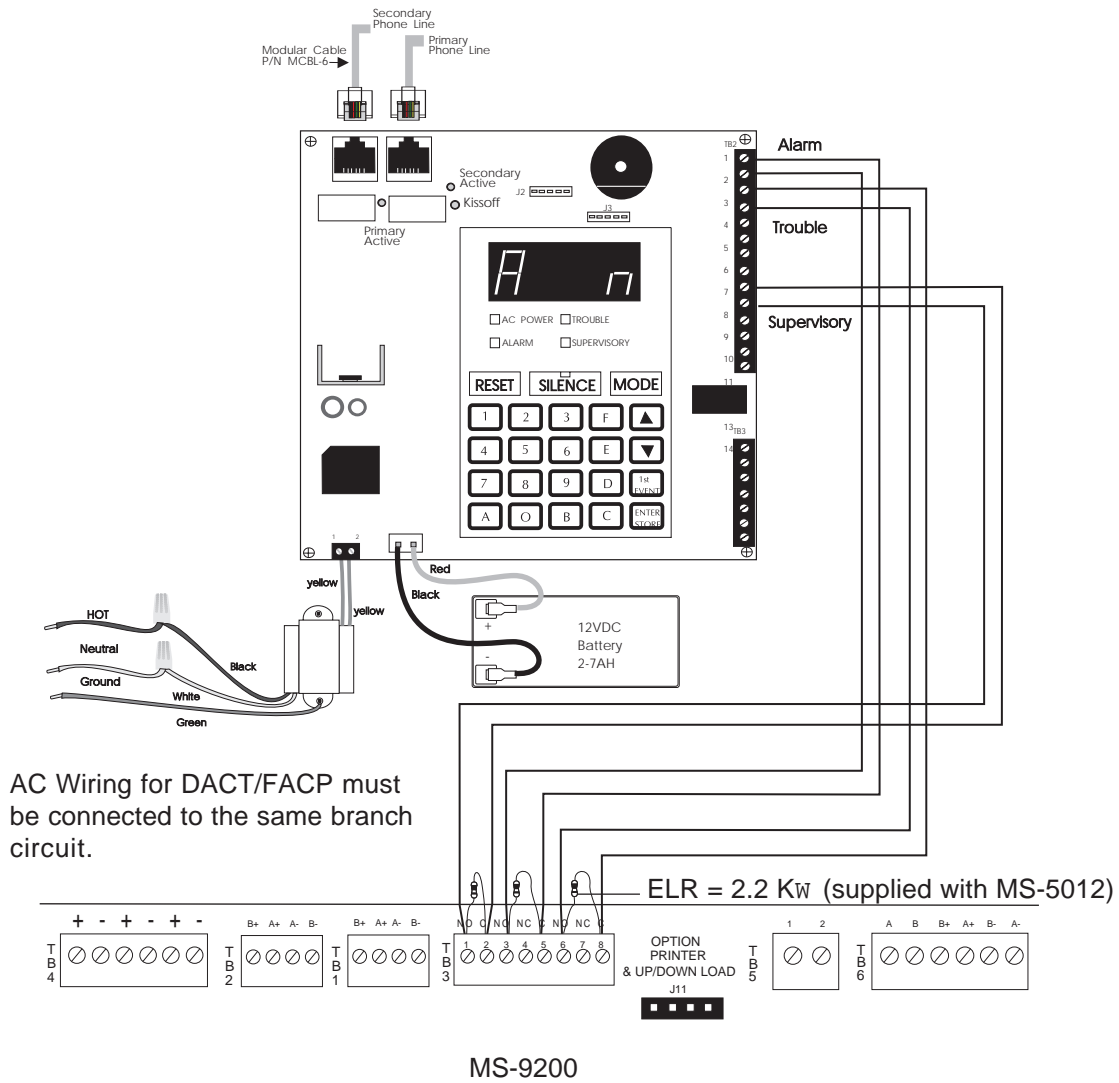
**NFPA 72-1993 Proprietary Fire Alarm System**

MS-9200 Alarm, Trouble and Supervisory contacts connected to Transmitter(s) . See Figure E-4 for installation instructions for this unit.



# Figure E-1: NFPA Signaling Systems for Central Station Service (Protected Premises Unit)

This Figure illustrates use of an MS-5012. The UDACT-F may also be used. Refer to Section II for information on installation.



MS-9200

	MS-5012	MS-9200
Alarm	TB2-1	TB3-5
	TB2-2	TB3-3
Trouble	TB2-3	TB3-8
	TB2-4	TB3-6
Supervisory	TB2-9	TB3-2
	TB2-10	TB3-1

**NOTES:**

- 1) Reference the MS-5012 Manual for additional information.
- 2) Program the MS-5012 for slave application.
- 3) SW2 Trouble/No AC switch located on bottom right of MS-9200 main circuit board, must be positioned in the down position for this application. This prevents the transmission of a trouble on the loss of AC power.

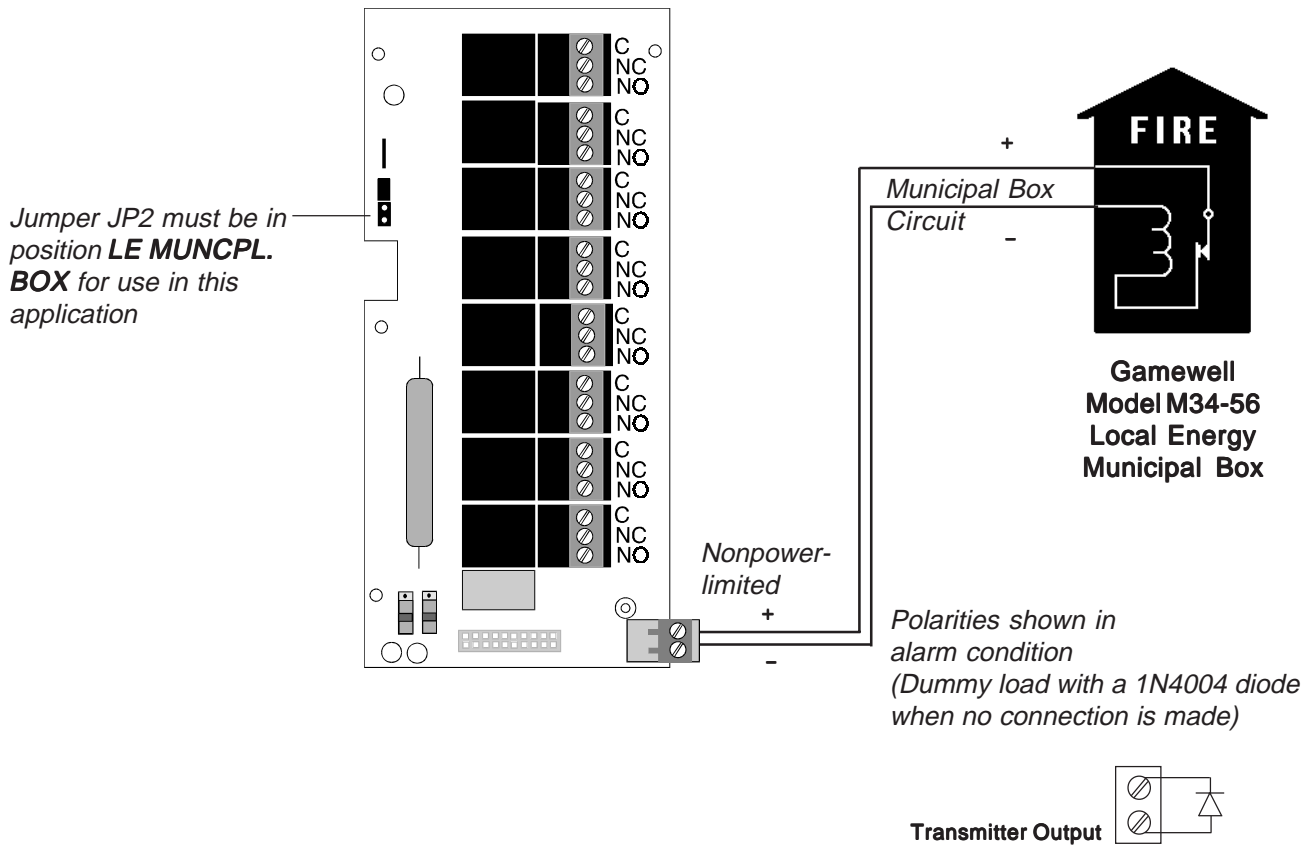
## Figure E-2: NFPA 72 Auxiliary Fire Alarm System

All connections are power limited and supervised. This application is not suitable for separate transmission of sprinkler supervisory or trouble conditions.

### NOTES:

- 1) 3 ohms maximum loop resistance allowed for wiring from control panel to Municipal Box.
- 2) Cut JP4 on MS-9200 System Board to supervise placement of RTM-8F Module and circuit.

### MUNICIPAL BOX CONNECTED TO RTM-8F RELAY TRANSMITTER MODULE

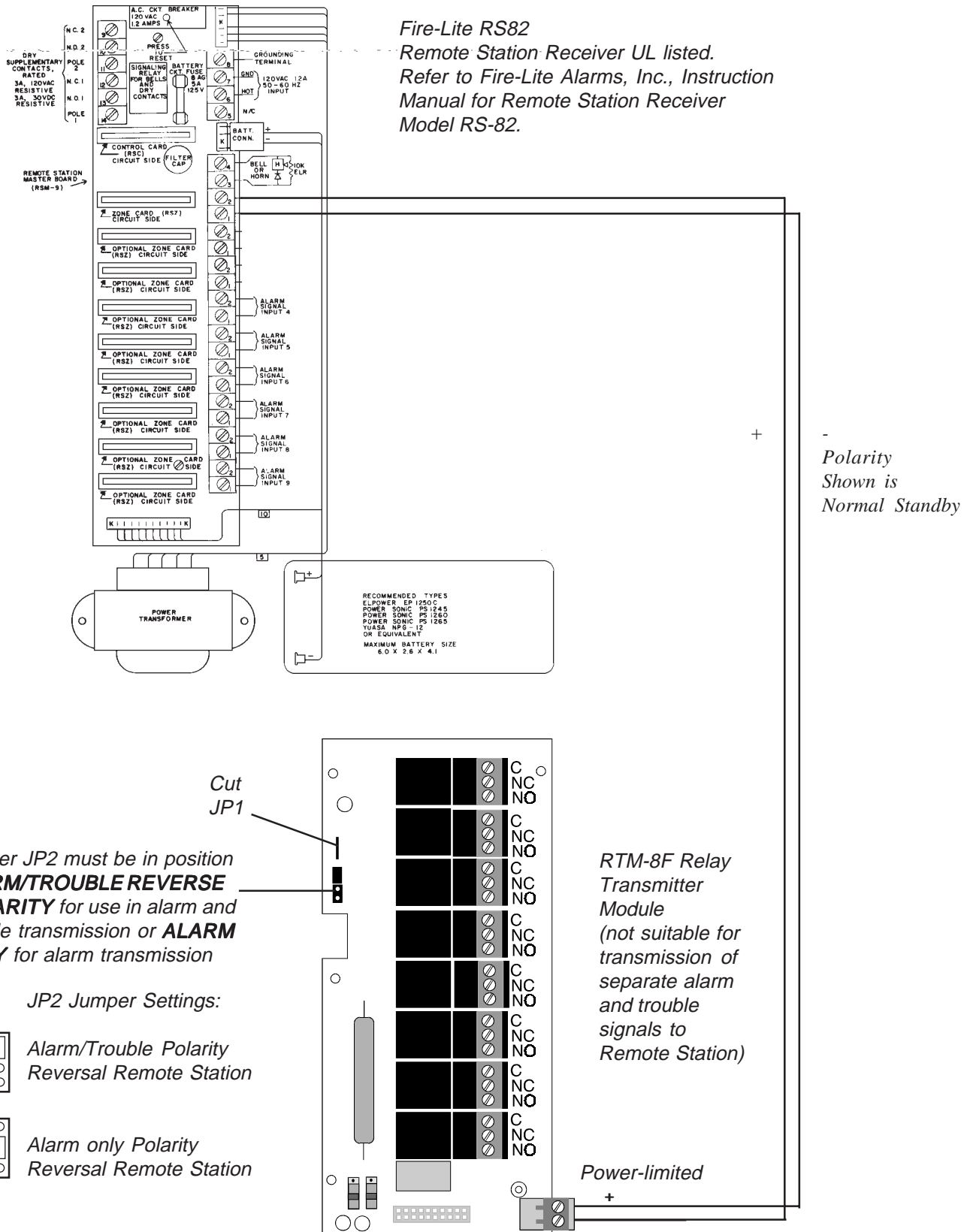


Note: Refer to Figure 2.4 and Section 2.5.1 for information on UL Power-limited wiring requirements.

**Figure E-3: NFPA 72 Remote Station Protective Signaling System**

**Remote Station Connection Using RTM-8F Module**

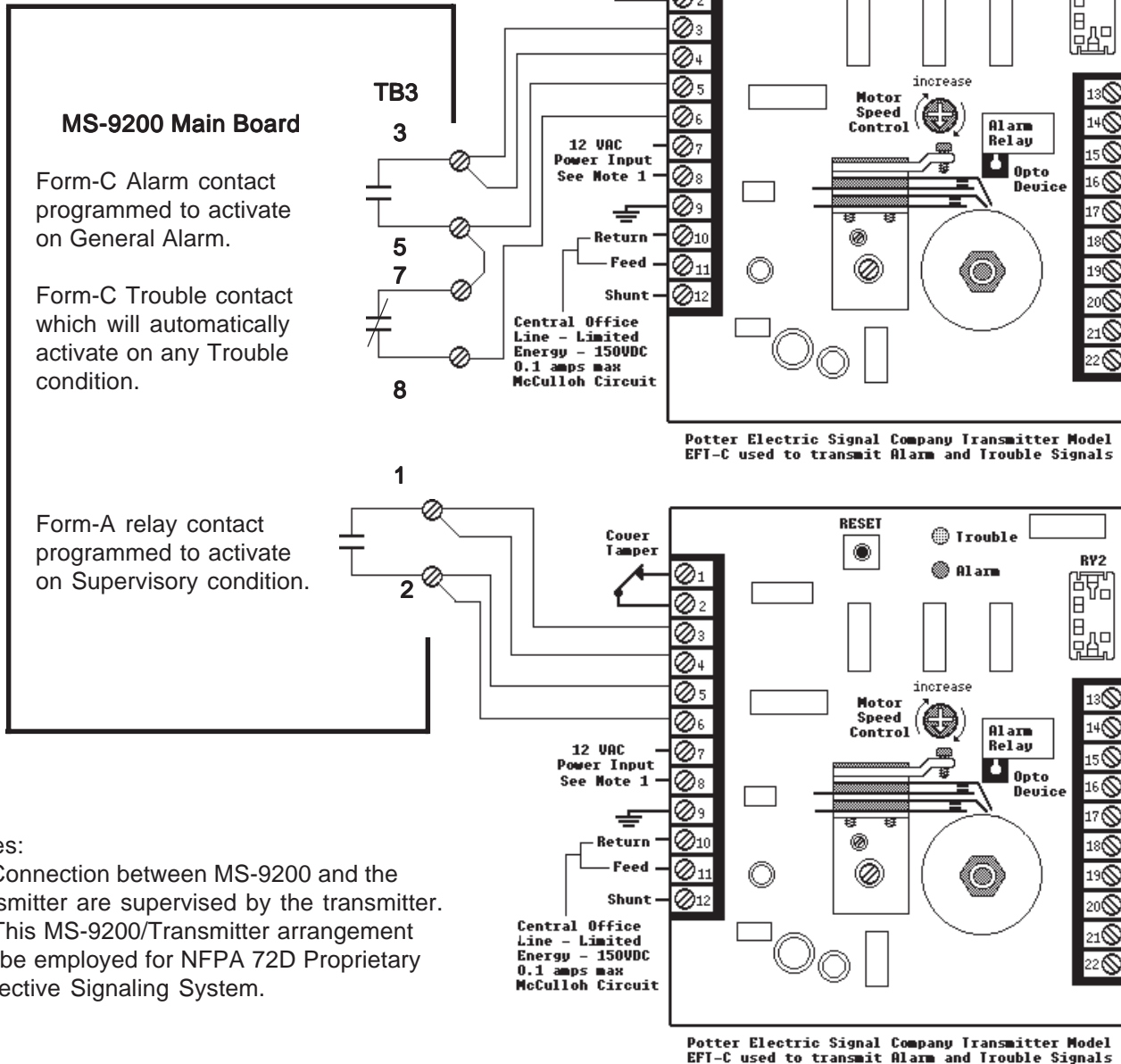
Note: Cut Jumper JP-4 on MS-9200 System Board to supervise placement of the RTM-8F module..



Note: Refer to Figure 2.4 and Section 2.5.1 for information on UL Power-limited wiring requirements.

Figure E-4: NFPA 72 Proprietary Protective Signaling Systems

MS-9200 Addressable Fire Control Panel



Notes:

- 1) Connection between MS-9200 and the transmitter are supervised by the transmitter.
- 2) This MS-9200/Transmitter arrangement can be employed for NFPA 72D Proprietary Protective Signaling System.

# APPENDIX F: WIRE REQUIREMENTS

T-tapping of the SLC loop wiring is allowed for two wire (Style 4) configurations. The total resistance of any branch cannot exceed 40 ohms. The total wire length of all combined branches cannot exceed 10,000 feet.

Connecting external system accessories to the MS-9200 main circuits must be carefully considered to ensure proper operation. It is important to use the correct type of wire, wire gauge, and wire run length per each MS-9200 circuit. Reference the chart below to specify wire requirements and limitations for each MS-9200 circuit.

NOTE: If the SLC Loop is to be run in conduit with Notification Appliance Circuits, the risk of encountering problems can be greatly reduced by exclusively employing electronic sounders (such as MA/SS-24D) instead of more electronically noisy notification appliances such as electromechanical bells or horns.

CIRCUIT CONNECTIONS		WIRE REQUIREMENTS		
CIRCUIT TYPE	CIRCUIT FUNCTION	WIRE TYPE AND LIMITATIONS	RECOMMENDED MAX DISTANCE (FEET)	WIRE GAUGE
SLC Loop (power-limited)	Connects to Addressable Devices	Twisted, shielded pair, 40 ohms maximum per length of Style 6 and 7 loops. 40 ohms per branch maximum for Style 4 loops <sup>1</sup>	10,000 8,000 4,875 3,225	12 AWG Signal 88202 Belden 9583 WPW999 14 AWG Signal 88402 Belden 9581 WPW995 16 AWG Signal 88602 Belden 9575 WPW991 18 AWG Signal 88802 Belden 9574 WPW975
		Untwisted, unshielded pair <sup>1</sup>	1,000	12-18 AWG
EIA-485 (power-limited)	Connects to annunciator modules	Twisted, shielded pair with a characteristic impedance of 120 ohms	6,000	18 AWG
EIA-232 (power-limited)	PIM-24 output connects to remote printer and PC computer	Twisted, shielded pair	50	18 AWG minimum
M300 and M301 (power-limited)	Initiating Device Circuit	Maximum loop wire resistance is 40 ohms for the M300 and 20 ohms for the M301	2,500	12-18 AWG
M302 (power-limited)	Initiating Device Circuit	No more than a 2.4 volt drop allowed at end of circuit. Maximum loop wire resistance is 25 ohms	2,500	12-18 AWG
C304 (power-limited)	Notification Appliance Circuit	In alarm, no more than a 1.2 volt drop allowed at end of circuit	Distance limitation set by 1.2 volt maximum line drop	12-18 AWG
24 VDC Regulated Resettable and Nonresettable (power-limited)	Connects to annunciators and other accessories	No more than 1.2 volt drop allowed from supply source to end of any branch	Distance limitation set by 1.2 volt maximum line drop	12-18 AWG
24 VDC Nonregulated (power-limited)	Connects to C304 control modules and accessories	No more than 1.2 volt drop allowed from supply source to end of any branch	Distance limitation set by 1.2 volt maximum line drop	12-18 AWG
R45-24E	Remote secondary power source	12 AWG in conduit	20	12-18 AWG

<sup>1</sup>When using untwisted, unshielded wire, full conduit is recommended for optimum EMI/RFI protection.

**Table F-1: 9200 Wire Specifications**

# APPENDIX G: Compatible Surge Suppressors

Surge suppressors are protective devices which are designed to limit surge voltages due to power line fluctuations, voltage transients or lightning. They can be placed on circuits to reduce the possibility of damage to sensitive equipment due to unexpected voltage surges. Table G-1 lists the surge suppressors which have been tested with the MS-9200 and have been found capable of reducing the risk of damage to the corresponding circuits due to voltage fluctuations.

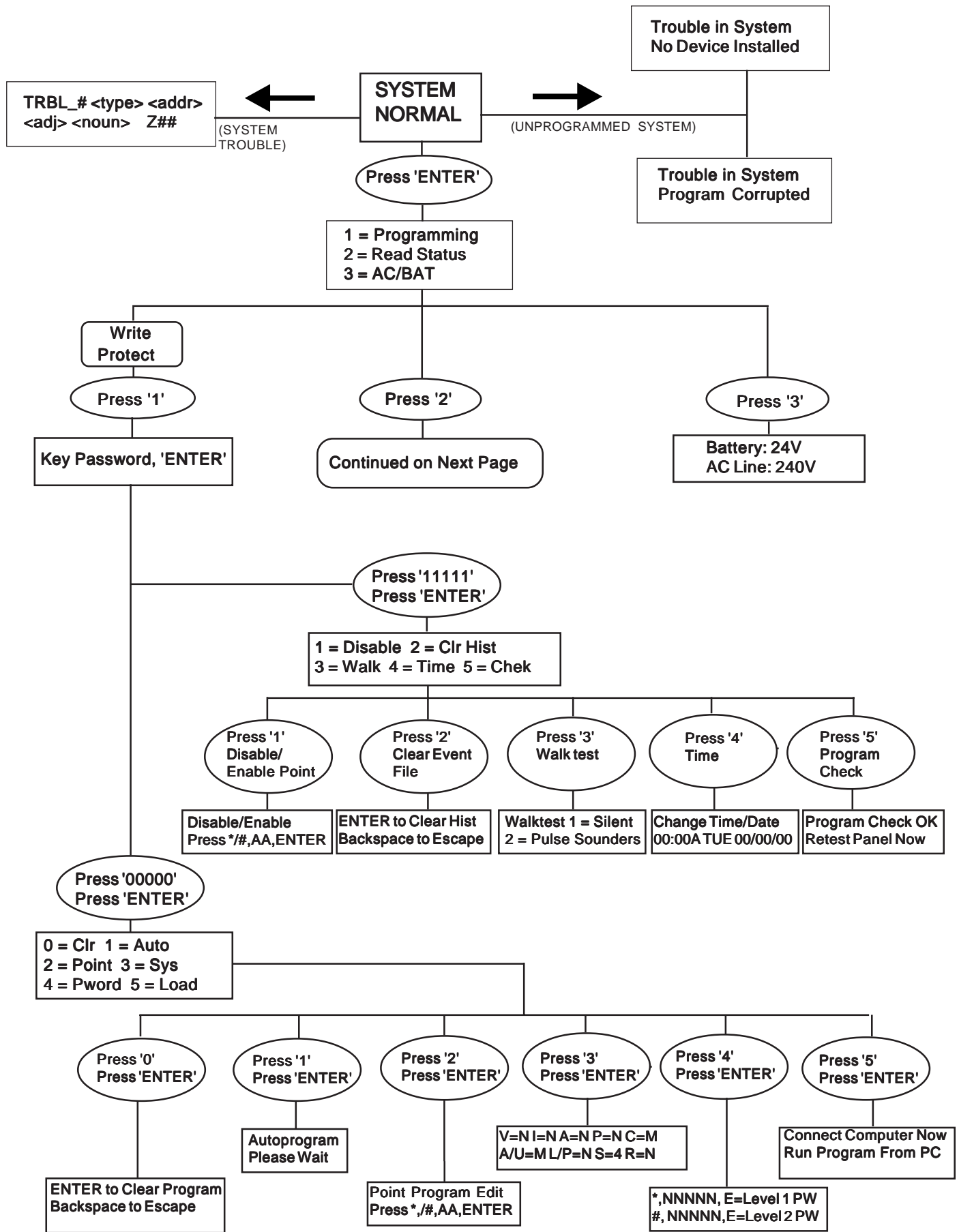
Surge Suppressors Compatible with FACP

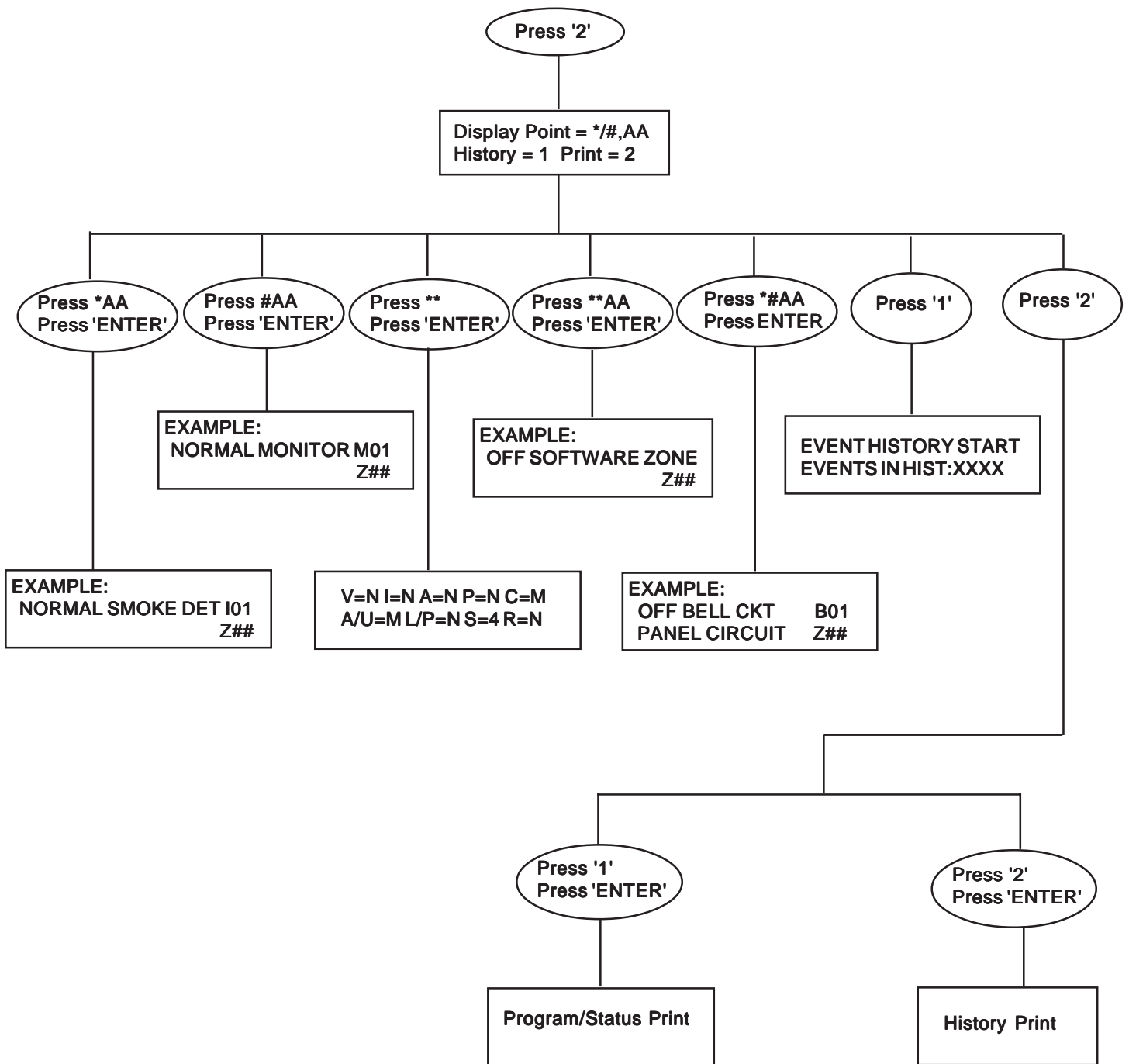
Manufacturer	Use the Following Models to Protect:			
	SLC Loop	RS-232	RS-485	Notification Appliances
Northern Technologies, Inc.	<u>DLP-DS1</u> has 24V relay Form-C contact, protects one pair	<u>DLP-DS1</u> has 24V relay Form-C contact, protects one pair	<u>DLP-DS1</u> has 24V relay Form-C contact, protects one pair	<u>DLP-43</u> protects one pair
	<u>DLP-42</u> protects two pair	<u>DLP-42</u> protects two pair	<u>DLP-42</u> protects two pair	
Eclips	<u>FA 24</u> protects one pair	<u>FA 24</u> protects one pair	<u>FA 24</u> protects one pair	Not available
Edco	<u>FAS-1-033HC</u> protects one pair	<u>PC642C-020</u> protects two pair	<u>PC642C-008LC</u> protects two pair	<u>FAS-1-060HC</u> protects one pair
	<u>FAS-2-033HC</u> protects two pair	<u>PCB1B</u> protects two pair	<u>PCB1B</u> protects two pair	<u>FAS-2-060HC</u> protects two pair
	<u>TER-030</u> protects one pair			<u>TER-060</u> protects one pair

Table G-1: Surge Suppressors

# APPENDIX H: SCREEN OPTIONS FLOWCHART

(Software P/N 73750 or greater)





LEGEND



Text inside box actually appears in LCD display



Text inside oval indicates key press



Write Protect Switch on MS-9200 motherboard









## **Limited Warranty**

**Fire-Lite**<sup>®</sup> warrants its products to be free from defects in materials and workmanship for eighteen (18) months from the date of manufacture, under normal use and service. Products are date stamped at time of manufacture. The sole and exclusive obligation of **Fire-Lite**<sup>®</sup> is to repair or replace, at its option, free of charge for parts and labor, any part which is defective in materials or workmanship under normal use and service. For products not under **Fire-Lite**<sup>®</sup> manufacturing date-stamp control, the warranty is eighteen (18) months from date of original purchase by **Fire-Lite**<sup>®</sup>'s distributor unless the installation instructions or catalog sets forth a shorter period, in which case the shorter period shall apply. This warranty is void if the product is altered, repaired or serviced by anyone other than **Fire-Lite**<sup>®</sup> or its authorized distributors or if there is a failure to maintain the products and systems in which they operate in a proper and workable manner. In case of defect, secure a Return Material Authorization form from our customer service department. Return product, transportation prepaid, to **Fire-Lite**<sup>®</sup>, 12 Clintonville Road, Northford, Connecticut 06472-1653.

This writing constitutes the only warranty made by **Fire-Lite**<sup>®</sup> with respect to its products. **Fire-Lite**<sup>®</sup> does not represent that its products will prevent any loss by fire or otherwise, or that its products will in all cases provide the protection for which they are installed or intended. Buyer acknowledges that **Fire-Lite**<sup>®</sup> is not an insurer and assumes no risk for loss or damages or the cost of any inconvenience, transportation, damage, misuse, abuse, accident or similar incident.

**Fire-Lite**<sup>®</sup> GIVES NO WARRANTY, EXPRESSED OR IMPLIED, OF MERCHANTABILITY, FITNESS FOR ANY PARTICULAR PURPOSE, OR OTHERWISE WHICH EXTEND BEYOND THE DESCRIPTION ON THE FACE HEREOF. UNDER NO CIRCUMSTANCES SHALL **Fire-Lite**<sup>®</sup> BE LIABLE FOR ANY LOSS OF OR DAMAGE TO PROPERTY, DIRECT, INCIDENTAL OR CONSEQUENTIAL, ARISING OUT OF THE USE OF, OR INABILITY TO USE **Fire-Lite**<sup>®</sup> PRODUCTS. FURTHERMORE, **Fire-Lite**<sup>®</sup> SHALL NOT BE LIABLE FOR ANY PERSONAL INJURY OR DEATH WHICH MAY ARISE IN THE COURSE OF, OR AS A RESULT OF, PERSONAL, COMMERCIAL OR INDUSTRIAL USE OF ITS PRODUCTS.

This warranty replaces all previous warranties and is the only warranty made by **Fire-Lite**<sup>®</sup>. No increase or alteration, written or verbal, of the obligation of this warranty is authorized.

"**Fire-Lite**" is a registered trademark.



**Fire-Lite**<sup>®</sup> **ALARMS**  
INCORPORATED

12 Clintonville Road, Northford, CT 06472  
Phone: (203) 484-7161  
FAX: (203) 484-7118